

### INTRODUCTION

The high accuracy differential pressure transmitter includes a pipe-to-pipe 3-valve manifold option. The manifold consists of two isolation (block) valves and an equalizer valve. The 3-valve manifold assembly simplifies installation, allows easy service without disruption of the process and reduces costs when compared to using individual components.

The high accuracy differential pressure transmitter is designed with dual remote sensors that enable it to accept high pressure in several ranges up to 500 PSI, 30 Bar or 3000 kPa. All models can handle overload pressure 2X and burst pressure 20X the maximum full-scale range.

Features include field selectable pressure ranges and output signal types, output reversal and slow damping, port swapping and bidirectional measurements for the most flexible applications. The pressure transmitter is fully factory calibrated and temperature compensated for the highest start-up accuracy.

**WARNING :** Ensure that the maximum individual port pressure does not exceed the highest pressure range of the unit. For example, the highest individual port pressure on a 102 Range Code is 100 PSI. Exceeding this may damage the sensors and give erroneous readings. See Figure 12 for ratings.

### BEFORE INSTALLATION

Read these instructions carefully before installing and commissioning the pressure transmitter. Failure to follow these instructions may result in product damage. Do not use this device in an explosive or hazardous environment, with combustible or flammable gases, as a safety or emergency stop device or in any other application where failure of the product could result in personal injury. **Follow electronic discharge precautions during installation and do not exceed the device ratings.**

### MOUNTING

Mount the assembly bracket on a vertical surface using the either two of the four integrated mounting holes as shown in Figure 1. The mounting holes will facilitate #10 size screws (not supplied). Ensure there is enough space around the device to make the electrical connections. Avoid locations with high vibrations or excessive moisture. The enclosure has a standard opening for a conduit connector or cable gland type fitting. When mounted in this position, the High port is on the left and the Low port is on the right as indicated on the sensor labels.

The enclosure has a hinged cover with a latch. Open the cover by pulling slightly on the latch on the bottom side of the enclosure and at the same time pulling on the cover, as illustrated in Figure 2.

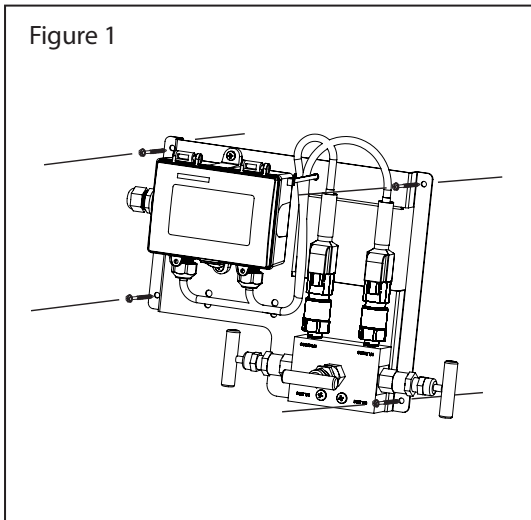

Figure 1

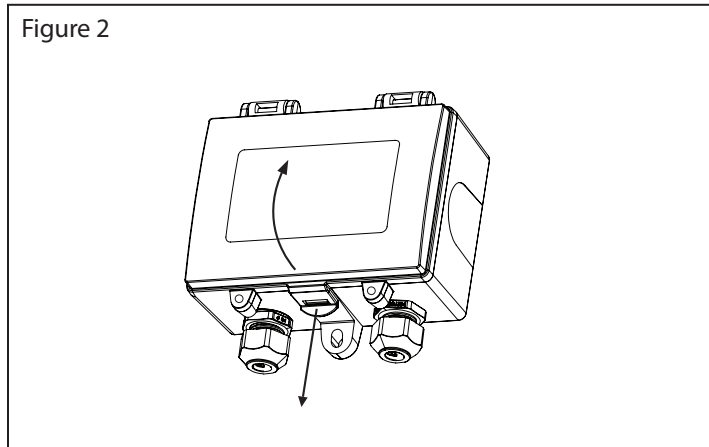

Figure 2

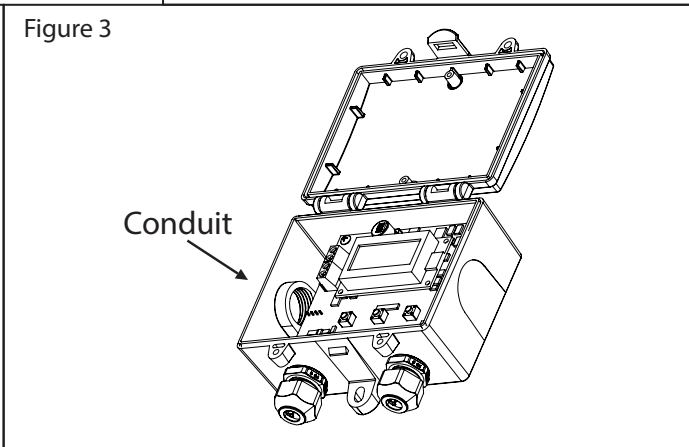

Figure 3

Figure 4

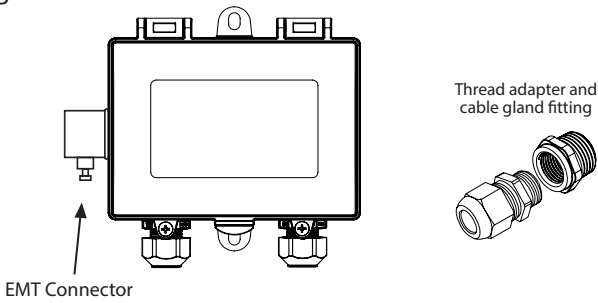
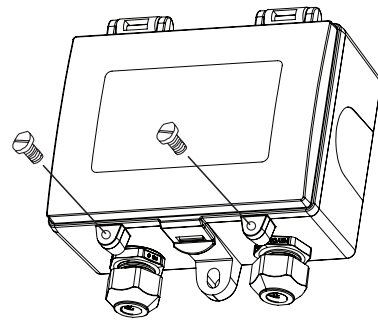

Figure 5



A 1/2" NPT threaded connection hole is provided in the left side of the enclosure as shown in Figure 3. Screw the EMT connector or cable gland connector in until tight. See Figure 4. It is recommended that weatherproof conduit or cable gland fittings be used. An optional 1/2" NPT to M16 thread adapter and cable gland fitting is available.

Two security screws are provided which can be installed to secure the cover once wiring connections and settings are complete. See Figure 5.

## PLUMBING

The manifold is constructed of one-piece 316 stainless steel for high strength and superior corrosion resistance and features a no-weld design for safety. The unit is 100% pressure tested for shut-off at all seals. Connections are 1/8" female NPT on 2 1/8" (54 mm) centers and bonnet lock pins are standard to prevent accidental valve disassembly.

The assembly is shipped with the Equalize valve open and both Isolation valves closed. Verify these valve positions before installation. After installation slowly open the Isolation valves to allow wetting of the sensors and to prevent hammering. Then close the equalization valve to start normal measurement of the differential pressure.

In normal operation the two Isolation valves are open and the Equalize Valve is closed to provide the differential pressure to the transmitter. To remove the transmitter without disturbing the process, simply open the Equalize valve first to equalize the pressure on the sensors and then close both Isolation valves.

Figure 6

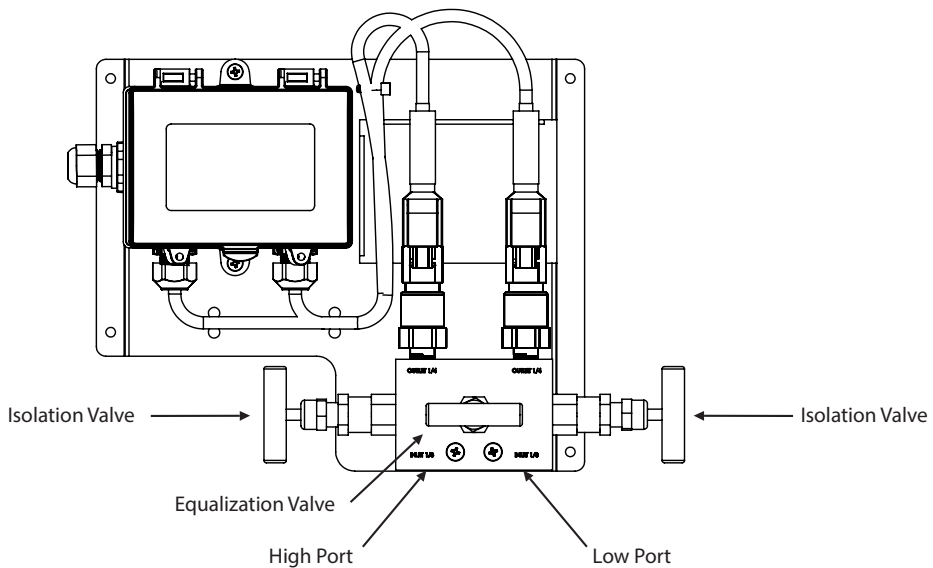
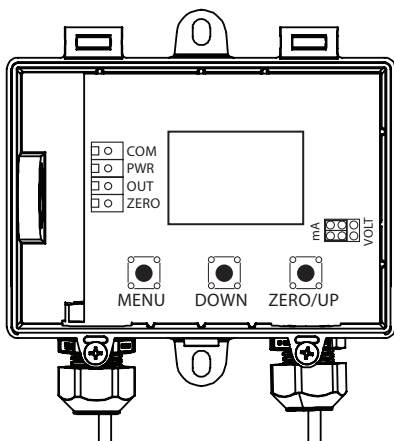

Figure 7



## CONFIGURATION

Most configuration is done using the User Menu, LCD and push buttons on the PCB. See the User Menu section for more details.

**WARNING: The transmitter must not have power applied during set up or when making changes to the output signal.**

**Output Selection:** The transmitter features user-selectable outputs signal of 4-20 mA, 0-5 Vdc and 0-10 Vdc. It is factory configured to operate in the Current (4-20 mA) mode but can be changed to Voltage mode by moving the output selection

jumper from the position marked mA to the position marked VOLT as shown in Figure 8.

In Voltage mode the output scale may be changed to either 0-5 or 0-10 Vdc by accessing the User Menu.

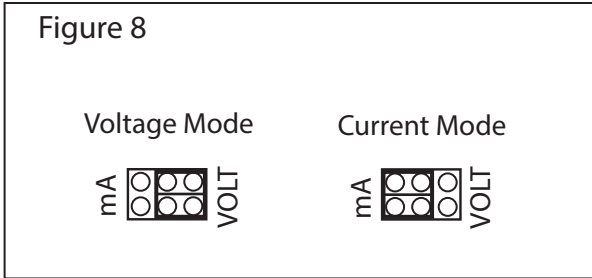

### WIRING

- Deactivate the 24 Vac/dc power supply until all connections are made to the device to prevent electrical shock or equipment damage.
- Use 14-22 AWG shielded wiring for all connections and do not locate the device wires in the same conduit with wiring used to supply inductive loads such as motors. Make all connections in accordance with national and local codes.
- Pull at least six inches of wire into the enclosure, then complete the wiring connection according to the wiring diagram for the applicable power supply and output signal type.
- Connect the plus DC or the AC voltage hot side to the PWR terminal. For voltage output or AC power, the supply Common is connected to the COM terminal. **DO NOT connect power to the OUT terminals as the device will be damaged.** It has half-wave power supply so the supply Common is the same as the signal Common. See Figure 9.
- The analog output is available on the OUT terminal. Check the controller Analog Input to determine the proper connection before applying power.
- If using the Zero function, connect the Remote Zero Switch between the ZERO and COM terminals.

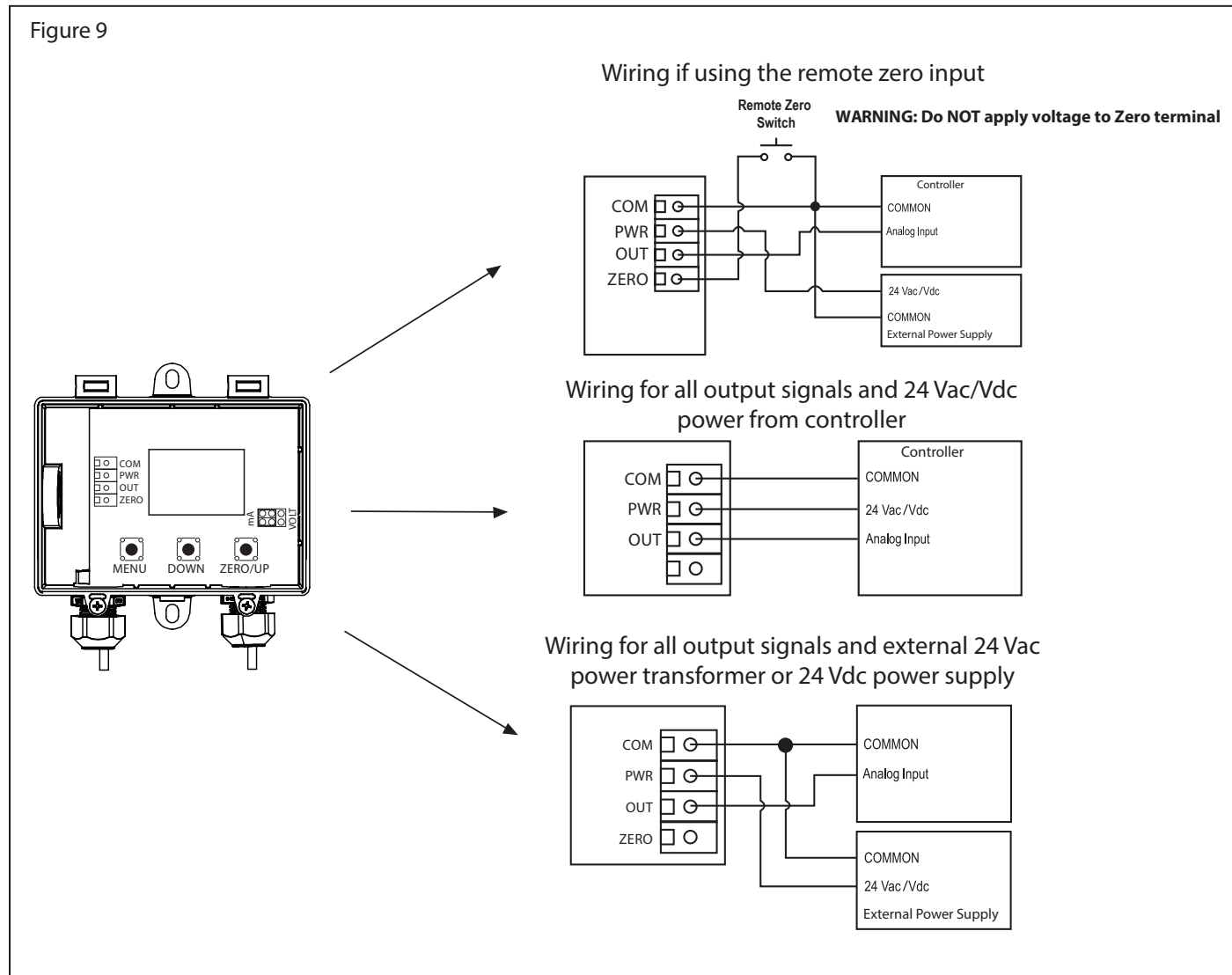

### START-UP

Upon applying power to the device, it will enter the start-up mode. The LCD will display the current operating settings for 2 seconds each.

#### 1. SOFTWARE VERSION NUMBER

Version  
1.00

#### 2. MODEL PRESSURE RANGE

P Range  
50PSI

### 3. THE OUTPUT TYPE

Output  
4-20mA

At the end of start-up mode the device will enter normal mode displaying pressure read from sensors.

0.0  
PSI

### USER MENU

The User Menu can be accessed by pressing the <MENU> key at any time after the start-up mode. Note that the <ZERO> key function changes to an <UP> key function when a menu is active.

The system suspends operation when in the menu and holds the last pressure value as the output value. If the User Menu is not active for 5 minutes (no key press), then the menu will exit and the device returns to normal operation.

The User Menu operation and parameters are explained below.

<MENU> Press and release the <MENU> key to enter the User Menu

### 1. OUTPUT

Output  
0-5 Vdc

This item only appears if the PCB jumper is in the VOLT position. Use <UP> or <DOWN> to set the output signal type to 0-5 or 0-10 Vdc. The factory default is 0-5 Vdc.

<MENU> Press to save and advance to next menu item

### 2. PRESSURE RANGE

P. Range  
500 PSI

The pressure range defaults to the largest range (1) of the device. Use <UP> or <DOWN> to step through the four available ranges specific to the model. Available options are shown below in Figure 12:

Figure 12	PRESSURE RANGE			
Model	1	2	3	4
01	50 PSI	25 PSI	10 PSI	5 PSI
02	100 PSI	50 PSI	20 PSI	10 PSI
03	250 PSI	125 PSI	50 PSI	25 PSI
04	500 PSI	250 PSI	100 PSI	50 PSI
05	5.0 Bar	2.5 Bar	1.0 Bar	0.5 Bar
06	7.0 Bar	3.5 Bar	1.4 Bar	0.7 Bar
07	10 Bar	5 Bar	2 Bar	1 Bar
08	35 Bar	17.5 Bar	7 Bar	3.5 Bar
09	500 kPa	250 kPa	100 kPa	50 kPa
10	700 kPa	350 kPa	140 kPa	70 kPa
11	1000 kPa	500 kPa	200 kPa	100 kPa
12	3500 kPa	1750 kPa	700 kPa	350 kPa

<MENU> Press to save and advance to next menu item

### 3. PRESSURE SCALE

P Scale  
0 - Max

The default pressure scale is unidirectional 0 to full-scale (ex: 0 - 500 PSI). Use <UP> or <DOWN> to toggle the setting to a bi-directional scale (ex: ± 500 PSI). The setting changes from "0 - Max" to "+/- Max".

<MENU> Press to save and advance to next menu item

## 4. DAMPING

*Damping*  
4 sec

The pressure averaging time for surge damping defaults to 4 seconds. This can be changed from 1 to 60 seconds using <UP> or <DOWN>.

<MENU> Press to save and advance to next menu item

## 5. OUTPUT

*Output*  
Direct

The analog output defaults to Direct (4-20 mA, 0-5 Vdc or 0-10 Vdc). Use <UP> or <DOWN> to change it to Reverse (20-4 mA, 5-0 Vdc or 10-0 Vdc).

<MENU> Press to save and advance to next menu item

## 6. PRESSURE PORT

*P. Port*  
Direct

The Pressure Port defaults to Direct (HIGH Port = High Pressure, LOW Port = Low Pressure). Use <UP> or <DOWN> to change it to Reverse (HIGH Port = Low Pressure, LOW Port = High Pressure) if it is necessary to swap the ports due to a plumbing error.

<MENU> Press to save and advance to next menu item

## 7. BACKLIGHT

*Backlite*  
Auto

The backlight operation defaults to Auto operation. It can be set to Off or On Auto using <UP> or <DOWN>. Auto means the LCD backlight only lights when a menu is accessed, off means it never lights and on means it is always on.

<MENU> Press to exit and return to normal operation.

## OPERATION

During normal mode the device reads the pressure sensors and calculates the pressure value depending on the selected pressure range. The pressure value is displayed on the LCD and set as the output value for the analog output. The output value is updated once per second.

For normal operation such as 0-100 PSI, the pressure applied to the High port must be higher than the pressure applied to the Low port. If the pressure connection is reversed then the transmitter will always output 4 mA. If the Low port is left open to ambient pressure, then the High port is used to measure a positive pressure and 0 PSI = 4 mA and 100 PSI = 20 mA.

For bidirectional operation such as  $\pm 100$  PSI, the pressure applied to the High port should be higher than the pressure applied to the Low port for a positive output response. Negative pressure is indicated if the High pressure is less than the Low pressure. In this case -100 PSI = 4 mA and +100 PSI = 20 mA. Since the transmitter is linear 0 PSI = 12 mA.

The output value may be affected by device settings such as the pressure damping time. The pressure averaging setting controls how many readings are averaged to form the output value. For example, if the pressure averaging value is set to 30 seconds then 30 one-second readings are stored and averaged to form the output value. The next second will add a new reading and delete the first to form a new 30 second average for output. The output gets updated every second with a new average reading. The averaging value can be set from 1 to 60 seconds via the User Menu.

During normal mode, the device also monitors the <ZERO / UP>, <DOWN> and <MENU> keys and takes appropriate action. The keys are used to access the User Menu. The device also monitors the Volt/mA jumper to determine the appropriate output scaling. The voltage span may be set via the User Menu to either 0-5 Vdc or 0-10 Vdc.

A sensor auto-zero can be initiated by pressing and holding the internal <ZERO> switch for at least 3 seconds. If both pressure ports are close to zero pressure, then the device will calibrate with a new zero point. The auto-zero can also be initiated by holding the ZERO terminal low for 3 seconds.

Generally, it is not recommended that a span calibration be performed in the field unless a high-quality calibrator with low differential pressure ranges is available and the temperature of the sensor can be maintained.

## SPECIFICATIONS

Power Supply .....	24 Vac/dc $\pm$ 10% (non-isolated half-wave rectified)
Consumption .....	75 mA max @ 24 Vdc
Output Signal.....	4-20 mA sourcing, 0-5/0-10 Vdc (switch selectable)
Output Drive .....	<b>Current:</b> 500 $\Omega$ max <b>Voltage:</b> 10K $\Omega$ min
Protection Circuitry.....	Reverse voltage protected, transient protected
LCD .....	35 x 15 mm (1.4 x 0.6"), 2-line x 8-character
Accuracy .....	$\pm$ 0.5% full scale of selected range (range 4 is $\pm$ 1%)
Stability .....	$\pm$ 0.25% FS typical (1 year)
Pressure Ranges .....	4 per model (menu selectable)
Media Compatibility.....	17-4 PH stainless steel
Proof Pressure .....	2X highest range per model
Burst Pressure .....	20X highest range per model
Maximum Line Pressure.....	= highest model range
Pressure Cycles .....	> 100 million
Surge Damping.....	1-60 seconds averaging (menu selectable)
Zero Adjust .....	Push-button and remote input
Sensor Operating Range.....	-40 to 105°C (-40 to 221°F)
Operating Environment .....	0 to 50°C (32 to 122°F), 10 to 90 %RH non-condensing
Pressure Connection .....	1/8" NPT female
Sensor Housing.....	IP67
Sensor Cable .....	Armored Flexible S/S
Wiring Connection.....	14-22 AWG screw terminal block
Enclosure .....	<b>B:</b> Polycarbonate, UL94-V0, IP65 (NEMA 4X) <b>F:</b> Same as, B with thread adapter (1/2" NPT to M16) and cable gland fitting
Dimensions.....	255 W x 215 H x 113.77 D mm (10.04" x 8.46" x 4.48")
Weight .....	2380g (83.95oz) - Including remote cables and sensors
Country of Origin.....	Canada

## DIMENSIONS

