



### INTRODUCTION

The high accuracy room RH transmitter uses a highly accurate and field-proven RH sensor in an attractive, low profile enclosure to monitor room relative humidity levels. Additional options include an occupancy override button, a communication jack, a fan speed switch, a slide-pot setpoint control, a resistive temperature sensor and a LED or LCD display. The RH output can be selected as a linear 4-20 mA, 0-5 or 0-10 Vdc signal.

### BEFORE INSTALLATION

Read these instructions carefully before installing and commissioning the device. Failure to follow these instructions may result in product damage. Do not use in an explosive or hazardous environment, with combustible or flammable gases, as a safety or emergency stop device or in any other application where

failure of the product could result in personal injury. **Take electrostatic discharge precautions during installation and do not exceed the device ratings.**

### MOUNTING

The high accuracy room RH transmitter installs directly on a standard electrical box and should be mounted five feet from the floor of the area to be controlled. Do not mount the sensor near doors, opening windows, supply air diffusers or other known air disturbances. Avoid areas where the detector is exposed to vibrations or rapid temperature changes.

The cover is hooked to the base at the top edge and must be removed from the bottom edge first. Use a small Phillips screwdriver to loosen the security screw as shown in Figure 1. (Complete removal of this screw is not required). Use the screwdriver to carefully pry each bottom corner if necessary. Tip the cover away from the base and sit it aside as shown in Figure 2.

The PCB must be removed from the base to access the mounting holes. Follow usual anti-static procedures when handling the PCB and be careful not to touch the sensors. The PCB is removed by pressing the enclosure base to unsnap the latch near the bottom edge, then the PCB can be lifted out of the base as shown in Figure 3.

Sit the PCB aside until the base is mounted on the wall. For added protection, place the PCB in the supplied anti-static bag.

Mount the base by screwing to an electrical box or directly to the wall as shown in Figure 4. The mounting hole locations are shown on page 3.

After the base is screwed to an electrical box or the wall using the appropriate holes, remove the PCB from the anti-static bag, feed connection wires through center hole and place the top of PCB into the PCB holders on backplate and snap bottom of PCB into place as shown in Figure 4.

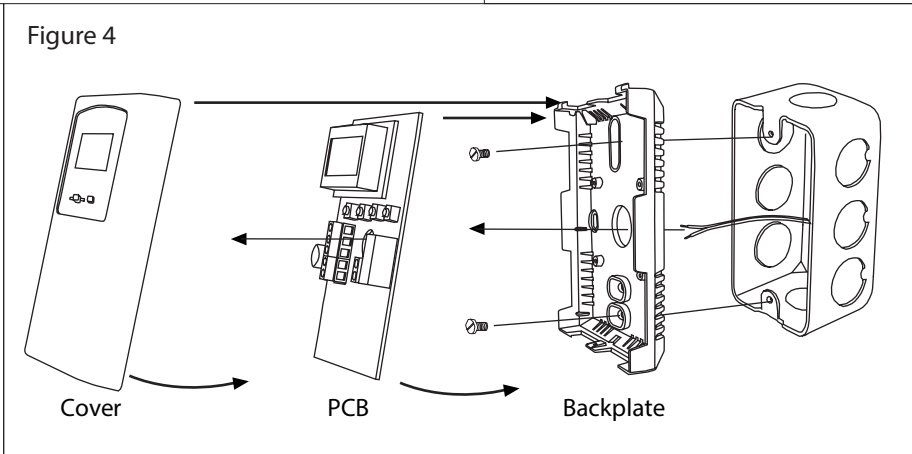
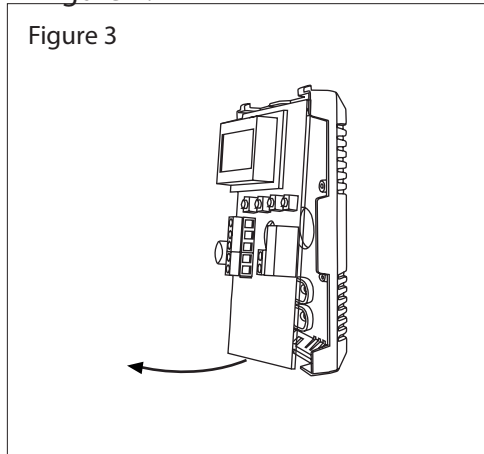
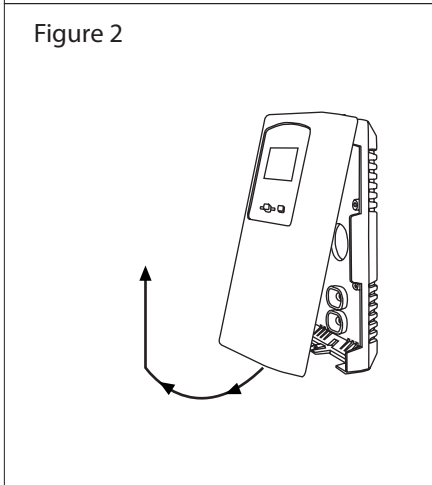
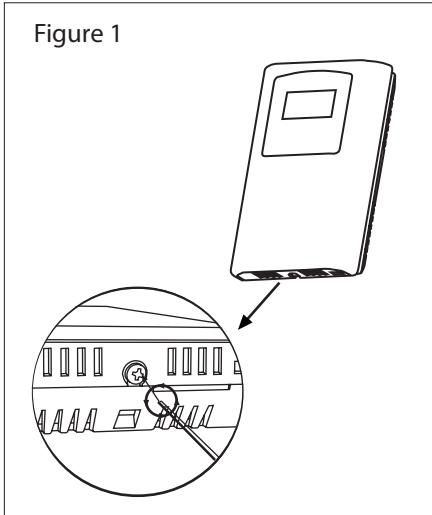
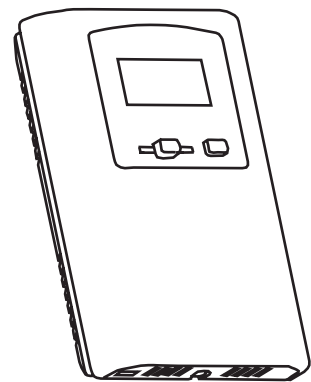

Make wire connections as per the Wiring Illustrations on Page 2 and install decorative cover by placing the top of the cover into the cover holder on the top of the backplate and snapping the bottom into place as shown in Figure 4. Tighten security screw with a Phillips screwdriver.

## WIRING

Deactivate the 24 Vac/dc power supply until all connections are made to the device to prevent electrical shock or equipment damage. Follow proper electrostatic discharge (ESD) handling procedures when installing the device or equipment damage may occur.

Use 22 AWG shielded wiring for all connections and do not locate the device wires in the same conduit with wiring used to supply inductive loads such as motors. Connect the cable shield to ground at the controller only. Make all connections in accordance with national and local codes.

Connector layout is shown in Figure 5. Diagram shown includes all options. If option is not ordered, connector will not be present.

For 4-20 mA two-wire loop-powered operation, only the POWER and OUTPUT terminals are required if a DC power supply is used. The COMMON terminal is only used for AC power or for a voltage output signal type. If the signal type is set to voltage, or a 24 volt AC power supply is used, connect the positive dc voltage or the hot side of the ac voltage to the terminal marked POWER and the power

Figure 5

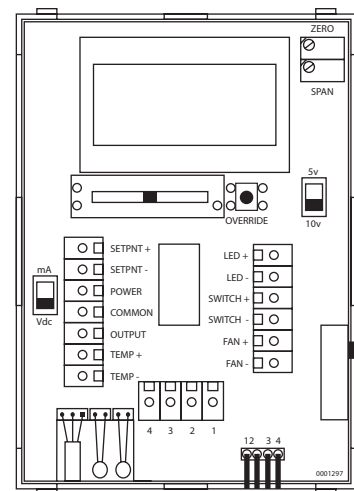
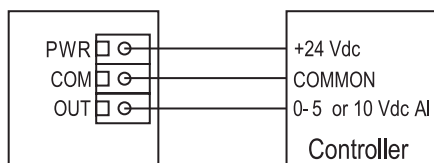
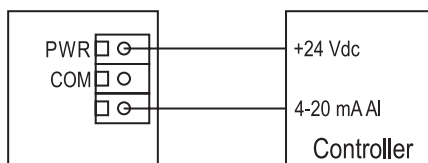

Figure 6

Wiring for voltage output signal and 24 Vdc power from controller



Wiring for 4-20 mA loop-powered output and external 24 Vdc power from controller



Wiring for all output signals and external 24 Vac power transformer

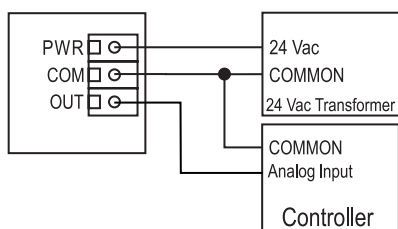

Wiring for 4-20 mA loop-powered output and external 24 Vdc external power supply

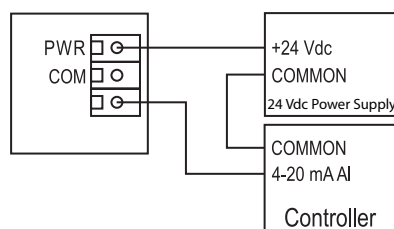

supply common is connected to the terminal marked COMMON. The device is reverse voltage protected and will not operate if connected backwards.

For three-wire voltage output operation, connect either an AC or DC power supply to POWER and COMMON and the voltage output signal is available on the OUTPUT terminal with respect to COMMON as shown in Figure 6.

Ensure the controller Analog Input (AI) matches the transmitter output signal type before power is applied and that the pcb switches are set correctly for the required signal type. The current signal has a maximum load that it will drive and the voltage signal has a minimum load rating. Follow the ratings in the Specification section or inaccurate readings may result.

This device has a half-wave power supply so the power supply common is the same as the signal common. Several devices may be connected to one power supply and the output signals all share the same common. Use caution when

Figure 7

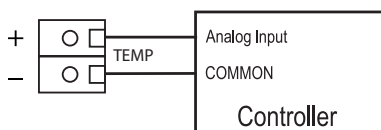

Figure 8

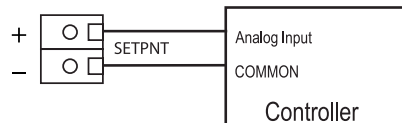
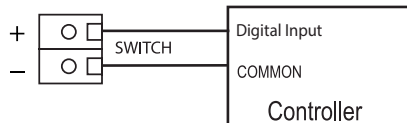

Figure 9



grounding the secondary of a transformer or when wiring multiple devices to ensure the ground point is the same on all devices and the controller.

The following optional features are only included if ordered. Wiring terminals are only present for features ordered.

An optional resistive temperature sensor may also be included in the device and is connected to the TEMP terminals as shown in Figure 7.

An optional resistive slide-pot setpoint output signal is available on the SETPNT + and SETPNT – terminals and can be configured with various resistance values and the operation can be set for forward or reverse acting as shown in Figure 8.

An optional override switch output is a dry-contact and is available on the SWITCH + and SWITCH – terminals and typically connects to a low voltage digital input of the controller to indicate room occupancy or override when the button is activated as shown in Figure 9.

Figure 10

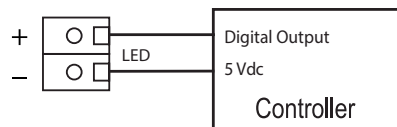

Figure 11

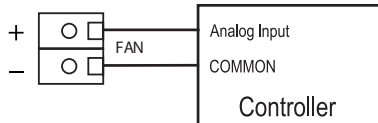

Figure 12

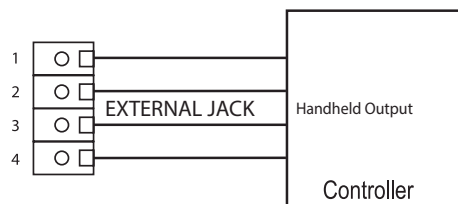

Figure 13

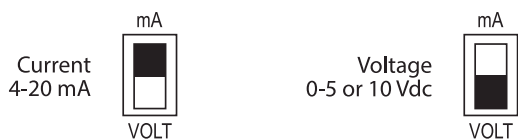

Figure 14



An optional LED input is typically powered by a 5 Vdc digital output from the controller and connects to the LED + and LED - terminals as shown in Figure 10.

An optional five position fan speed output signal is configured with five different resistive values and is available on the FAN + and FAN – terminals as shown in Figure 11.

An optional external jack is internally connected to a four-pin terminal block labeled 1, 2, 3 and 4 and accepts a four-pin header connector for remote communication with the controller as shown in Figure 12.

## START-UP

Verify that the transmitter is properly wired, connections are tight and the mA / Vdc switch is in the correct position as shown in Figure 13. For voltage output, also ensure the 5V / 10V switch is set correctly for the required signal type as shown in Figure 14. Apply power and note that the LCD will begin displaying the RH level (if installed). The output signal will also be available immediately after start-up.

## OUTPUT SIGNAL

The RH output is scaled such that 4-20 mA (or 0-5 or 0-10 Vdc) equals 0-100 %RH and is temperature compensated over the full 0-50 °C temperature range.

## DIMENSIONS

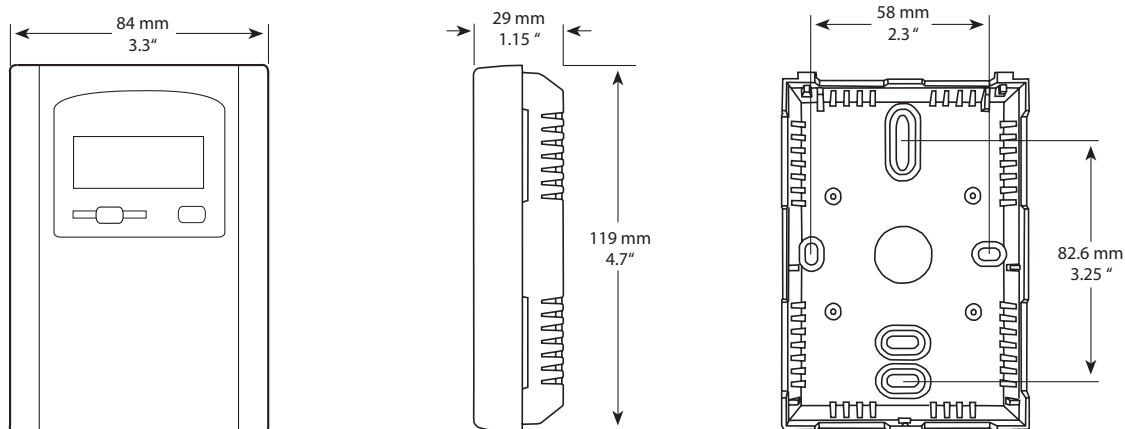

# SPECIFICATIONS

Sensor .....	Thermoset polymer based capacitive
Accuracy .....	±1% (20 to 80 %RH) ±2% (5 to 95 %RH)
Range.....	0 to 100% RH non-condensing
Hysteresis .....	± 3% RH
Reponse Time .....	15 seconds typical
Stability .....	±1.2% RH typical @ 50% RH in 5 years
Power Supply .....	24 Vac/dc ±10% (non-isolated half-wave rectified)
Consumption @ 24 Vdc .....	20 mA
Input Voltage Effect .....	Negligible over specified operating range
Output Signal.....	4-20 mA current loop, 0-5 Vdc or 0-10 Vdc - Jumper selectable
Output Drive @ 24 Vdc .....	<b>Current:</b> 550Ω maximum <b>Voltage:</b> 10KΩ minimum
Output Resolution .....	10 bit PWM
Internal Adjustments .....	ZERO and SPAN pots
Protection Circuitry.....	Reverse voltage protected, overvoltage protected
Operating Conditions .....	0 to 50°C (32 to 122°F), 0 to 95 %RH non-condensing
Enclosure Dimensions .....	84mm W x 117mm H x 29mm D (3.3" x 4.6" x 1.15")
Enclosure Material.....	White ABS, IP30 (NEMA 1)
Weight.....	5.3 oz (150 gm)
Country of Origin.....	Canada

## OPTIONAL LCD DISPLAY

Range.....	00.0 to 99.9 %RH, 3 digit
Size.....	38.1 mm x 16.5 mm (1.5" x 0.65")
Digit Height .....	11.43 mm (0.45")
Symbol .....	% RH

## OPTIONAL TEMPERATURE SENSOR

Sensor Type .....	Various thermistors or RTD
Sensor Accuracy.....	<b>RTD Class A:</b> ±0.15°C (±0.27°F) @ 0°C (32°F) <b>RTD 1/3 DIN:</b> ±0.1°C (±0.18°F) @ 0°C (32°F) <b>RTD 1/10 DIN:</b> ±0.03°C (±0.054°F) @ 0°C (32°F) <b>NTC Thermistor Type 39:</b> ±0.05°C (±0.09°F), 0 to 70°C (32 to 158°F) <b>NTC Thermistor Type 55:</b> ±0.03°C (±0.054°F), 0 to 70°C (32 to 158°F) <b>NTC Thermistor Type 40/46:</b> ±0.1°C (±0.18°F), 0 to 70°C (32 to 158°F)

## OPTIONAL SETPOINT ADJUSTMENT

Type.....	Front panel pot, two wire resistive output, 0-10K Ω
Range.....	0K to 10K Ω standard
Custom spans available.....	1K, 2K, 5K, 10K or 20K Ω

## OPTIONAL MANUAL OVERRIDE

Type.....	Front panel, momentary pushbutton
Switch ratings .....	50 mA @ 12 Vdc, N.O., SPST

## OPTIONAL STATUS LED INPUT (N/A WHEN LCD SELECTED)

Signal Type.....	5 V current limited, 2-wire standard
Color.....	Yellow (Y), Red (R), or Green (G)
Power Supply .....	5 Vdc standard, 10 or 24 Vdc optional

## OPTIONAL COMMUNICATION JACKS

Molex .....	4-pin header connector to 4-pin terminal block Requires HHTA - Hand Held Adapter
-------------	---

## OPTIONAL FAN SPEED SWITCH

Type.....	Side mounted, 5 position slide switch
Range.....	Off, Auto, Low, Medium, High
Signal .....	2 wire resistance output : 0, 2, 4, 6, 8K Ω (Custom ranges available, contact Greystone)

**NOTE:** The sensor accuracies listed in the specifications section apply to the sensing element only prior to product assembly and may not be reflected in the complete assembly.

Due to the measurement uncertainty, it is possible, that the true resistance value of the single delivered sensor at 0°C can be out of the defined tolerance class. Profiling each assembly to take into consideration lead wire and the attachment method should be completed.