

INTRODUCTION

This humidity transmitter uses a highly accurate and reliable Thermoset Polymer based capacitance humidity sensor and state-of-the-art digital linearization and temperature compensated circuitry in an attractive, low profile enclosure to monitor room humidity levels. Additional options are available which include manual override & LCD display.

BEFORE INSTALLATION

Read these instructions carefully before installing and commissioning the humidity transmitter. Failure to follow these instructions may result in product damage. Do not use in an explosive or hazardous environment, with combustible or flammable gases, as a safety or emergency stop device or in any other application where failure of the product could result in personal injury. Take electrostatic discharge precautions during installation. **Do not exceed the device ratings.**

MOUNTING

The humidity sensor installs on a standard electrical box or can be mounted directly to the wall. The backplate is configured to be compatible with many different electrical boxes types. The humidity transmitter should be mounted five feet from the floor of the area to be controlled. Do not mount the sensor near doors, opening windows, supply air diffusers or other known air disturbances. Avoid areas where the sensor is exposed to vibrations or rapid temperature changes.

Begin by removing the cover. Grasp the bottom of the cover and pull outward from the backplate as shown in Figure 1. Set cover aside. Do not remove the PCB from the enclosure base.

Feed at least 6" of wire through the wall and out of the junction box. Feed connection wires through center hole on backplate and PCB, then secure backplate to electrical box or wall with suitable screws (not supplied) as shown in Figure 3. The mounting holes in allow for up/down & side to side movement to compensate for unlevel electrical box installation.

Make wire connections as per the "Wiring illustrations" on Page 2 and re-install decorative cover by placing the top of the cover into the cover holders on the top of the backplate and snapping the bottom into place.

Two 1/16" Allen Key set screws are provided on the bottom of enclosure to add security and lock cover in place. To engage, insert Allen Key and turn counter-clockwise 2-3 rotations. As seen in Figure 4.

Figure 1

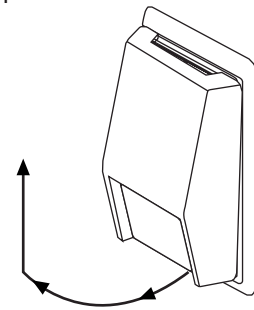

Figure 2

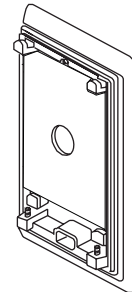

Figure 3

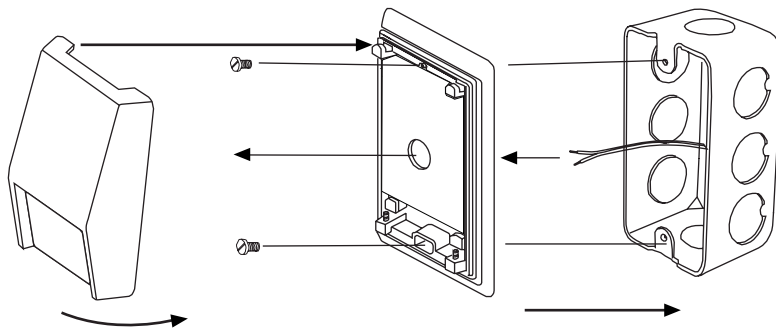
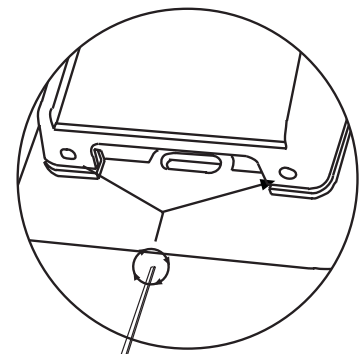
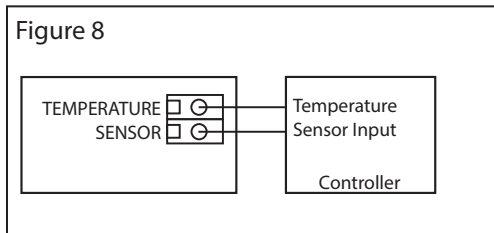
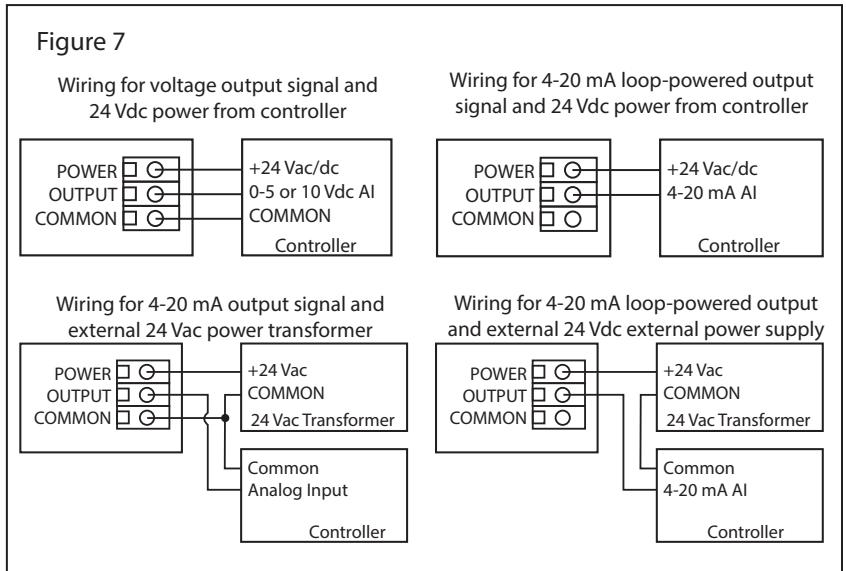
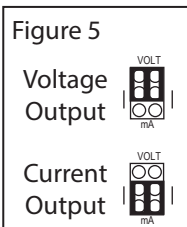
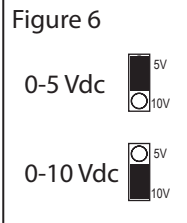
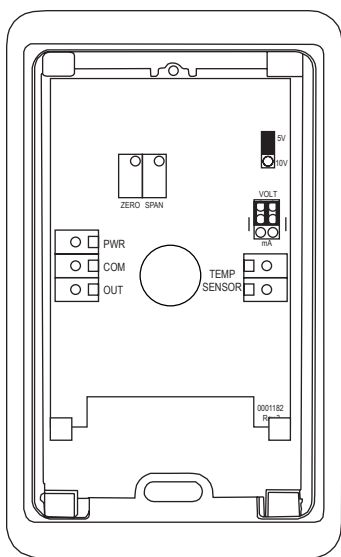

Figure 4



WIRING

- Deactivate the 24 Vac/dc power supply until all connections are made to the device to prevent electrical shock or equipment damage.
- Select desired signal output type by placing the output jumper in required position, as shown in Figure 5. Please note that pin connection tabs in jumper must be in vertical position.
- If voltage output is required, place Voltage Span Jumper to desired span position, as shown in Figure 6. I.E. 10 = 0-10 Vdc.
- Connect the plus dc or ac voltage hot side to the POWER terminal. For voltage output or AC power, the supply common is connected to the COMMON terminal. The device is reverse voltage protected and will not operate if connected backwards. It has a half-wave power supply so the supply common is the same as the signal common. See Figure 7.
- The analog output is available on the RH OUTPUT terminal. Check the controller Analog Input to determine the proper connection before applying power. See Figure 7.
- If installed, the resistance temperature signal is available on the two terminals labeled TEMPERATURE SENSOR. See Figure 8.



SPECIFICATIONS

Sensor Type	Thermoset polymer based capacitive
Accuracy	±2, 3, or 5 %RH (5 to 95 %RH)
Measurement Range	0 to 100 %RH
Temperature Dependence	±0.05 %RH/°C
Hysteresis	±1.5 %RH maximum
Repeatability	±0.5 %RH typical
Linearity	±0.5 %RH typical
Sensor Response Time	15 seconds typical
Stability	±1 %RH typical at 50 %RH in 5 years
Operating Temperature	0 to 50°C (32 to 122°F)
Operating Humidity	0 to 95 %RH non-condensing
Power Supply	18 to 35 Vdc, 15 to 26 Vac
Consumption	22 mA maximum
Input Voltage Effect	Negligible over specified operating range
Protection Circuitry	Reverse voltage protected and output limited
Output Signal	4-20 mA current loop, 0-5 or 0-10 Vdc (jumper selectable)
Output Drive @ 24 Vdc	Current: 550Ω max Voltage: 10KΩ min
Internal Adjustments	Clearly marked ZERO and SPAN pots
Wiring Connections	Screw terminal block (14 to 22 AWG)
Optional Temp Sensor	Various RTDs and thermistors available as two wire resistance output
Enclosure	White ABS, IP20 (NEMA 1)
Dimensions	70W x 114H x 30D mm (2.75" x 4.5" x 1.2")
Country of Origin	Canada

DIMENSIONS

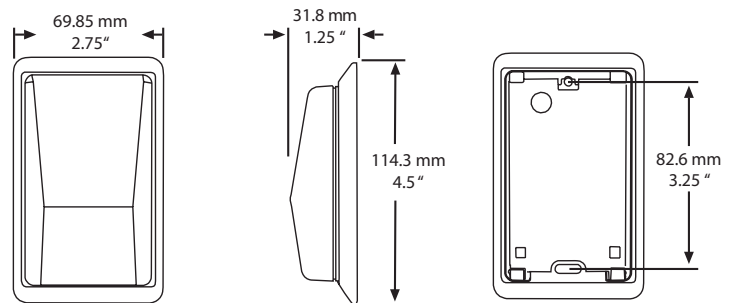

PRINTED IN CANADA