

#### INTRODUCTION

The room humidity/temperature transmitter series uses a highly accurate and reliable Thermoset Polymer based capacitance humidity sensor and Platinum RTD temperature sensor together with state-of-the-art digital linearization and temperature compensated circuitry to monitor humidity levels in a room.

#### BEFORE INSTALLATION

Read these instructions carefully before installing and commissioning the humidity/temperature transmitter. Failure to follow these instructions may result in product damage. Do not use in an explosive or hazardous environment, with combustible or flammable gases, as a safety or emergency stop device or in any other application where failure of the product could result in personal injury. **Take electrostatic discharge precautions during installation and do not exceed the device ratings.**

#### MOUNTING

The room transmitter installs directly in an electrical wall box, or can be mounted directly to the wall. The backplate is configured to be compatible with many different electrical box types. The temperature sensor should be mounted five feet from the floor of the area to be controlled. Do not mount the sensor near doors, opening windows, supply air diffusers or other known air disturbances. Avoid areas where the sensor is exposed to vibrations or rapid temperature changes.

Begin by removing the cover. Grasp the bottom of the cover and pull outward from the backplate as shown in Figure 1. Set the cover aside. Do not remove the PCB from the enclosure base.

Feed at least 6 inches of wire through the wall and out of the junction box. Feed connection wires through the center hole on the backplate and the PCB, then secure the backplate to the electrical box or wall with suitable screws (not supplied) as shown in Figure 2. The mounting holes allow for up/down and side to side movement to compensate for unlevel electrical box installation.

Make wire connections as per the "Wiring Illustrations" on Page 2.

Re-install decorative cover by placing the top of the cover into the cover holders on the top of the backplate and snapping the bottom into place.

Two 1/16" Allen Key set screws are provided on the bottom of the enclosure to add security and lock cover in place. To engage, insert Allen Key and turn counter-clockwise 2-3 rotations. As seen in Figure 3.

Figure 1

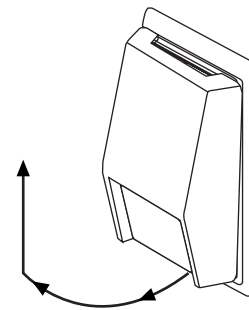

Figure 2

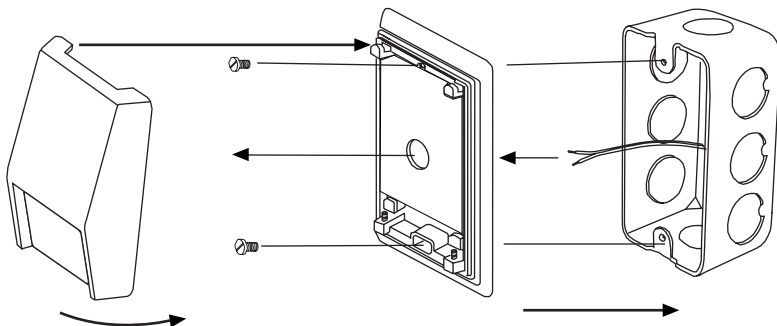
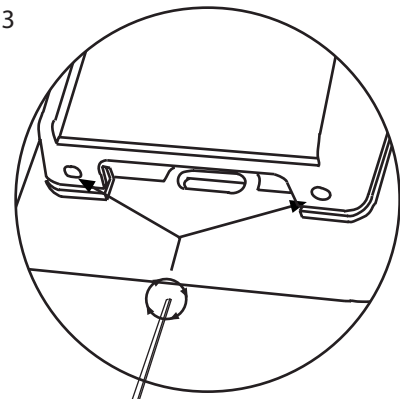
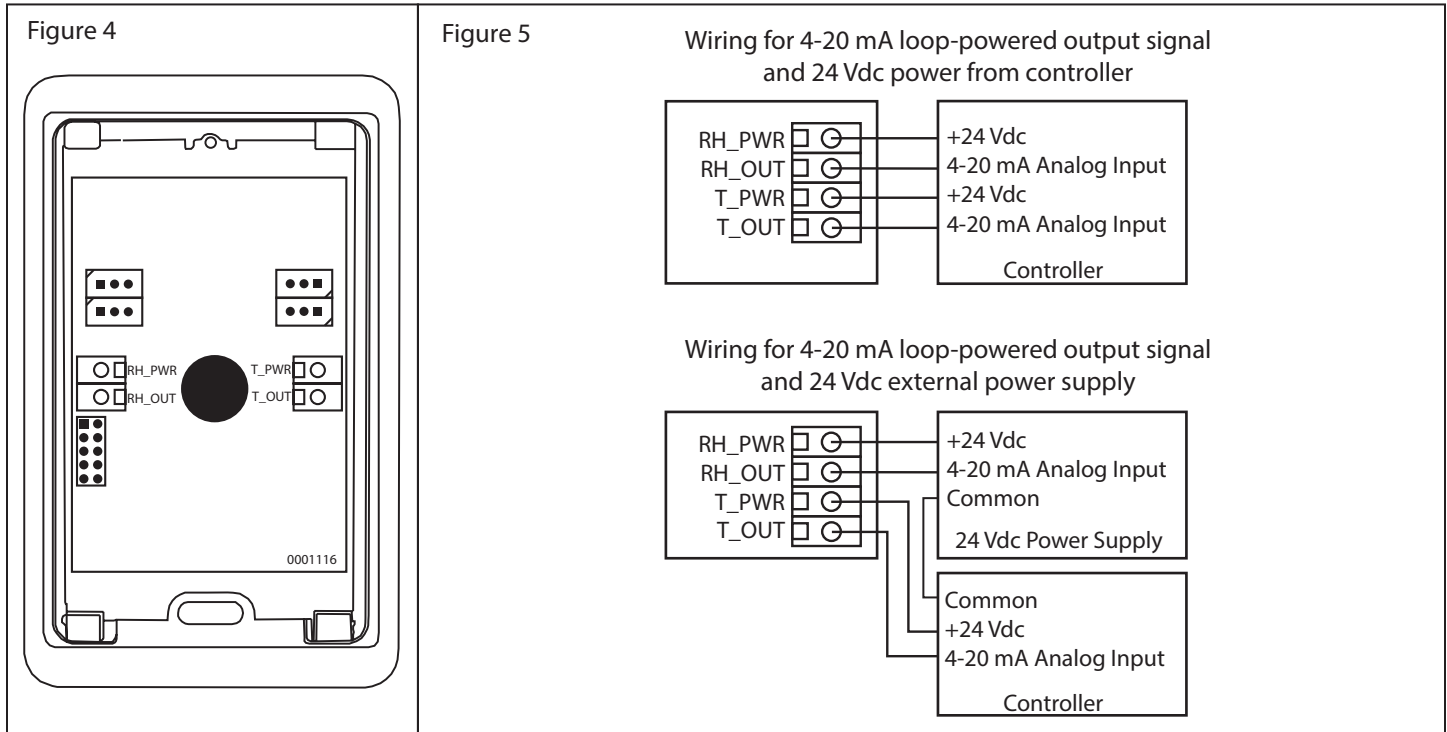

Figure 3



## WIRING

- Deactivate the 24 Vdc power supply until all connections are made to the device to prevent electrical shock or equipment damage.
- Use 18-22 AWG shielded wiring for all connections and do not locate the device wires in the same conduit with power cables as signal degradation may occur.
- Pull at least six inches of wire into the enclosure, then complete the wiring connections according to the wiring diagram for the applicable power supply and output signal type.
- The use of shielded cable is optional but recommended for the highest noise immunity.
- The controller analog input must be selected to match the transmitter output before power is applied
- Analog input type must be a current input with 350 or 500  $\Omega$  impedance.
- The transmitter board should not be mounted where temperatures will exceed these values.



## TYPICAL WIRE RESISTANCE VALUES

When using low resistance sensors (i.e. 100  $\Omega$  RTD), long wire runs can add significant error to the readings. Use the following chart to determine errors due to wire resistance or consider using 1000  $\Omega$  sensor or a transmitter for better accuracy. Locate the type of wire being used. Multiply the total length of the wire (distance from the controller to the sensor and back) by the number found in the following chart for total resistance.

GAGE WIRE TYPE	18 AWG	22 AWG	24 AWG
STRANDED (OHMS/FOOT)	5.85 m $\Omega$	14.75 m $\Omega$	23.29 m $\Omega$
SOLID (OHMS/FOOT)	6.4 m $\Omega$	15.85 m $\Omega$	25.72 m $\Omega$

## SPECIFICATIONS

Accuracy .....  $\pm 2, 3, 5$  %RH  
 $\pm 0.1\%$  FSO (Temp)  
 Power Supply ..... 24 Vdc  
 Output ..... 4-20 mA, loop powered (scaled 0-100%)  
 Operating Temperature ..... 0 to 50°C (32 to 122°F)  
 Wire Connections ..... Screw terminal block (18 to 22 AWG)  
 Enclosure ..... White ABS, IP20 (NEMA 1)  
 Dimensions ..... 70mm W x 114mm H x 30mm D (2.75" x 4.5" x 1.2")  
 Country of Origin ..... Canada

## DIMENSIONS

