

INTRODUCTION

The humidity and temperature transmitter incorporates two sensors in one attractive wall mount enclosure for the most efficient environmental monitoring and control system. It uses a field-proven RH sensor to monitor relative humidity and a curve-matched thermistor to measure temperature. Two set-point controls are also available for temperature and RH adjustment. The device may also include an occupancy override button and an external communication jack. Both measurements a set-point signals are available on separate outputs as linear 4-20 mA, 0-5 or 0-10 Vdc signals.

BEFORE INSTALLATION

Read these instructions carefully before installing and commissioning the device. Failure to follow these instructions may result in product damage. Do not use in an explosive or hazardous environment, with combustible or flammable gases, as a safety or emergency stop device or in any other application where failure of the product could result in personal injury. Take electrostatic discharge precautions during installation. **Do not exceed device ratings.**

MOUNTING

The transmitter installs directly on a standard electrical box and should be mounted five feet from the floor of the area to be controlled. Do not mount the sensor near doors, opening windows, supply air diffusers or other known air disturbances. Avoid areas where the detector is exposed to vibrations or rapid temperature changes.

The cover is hooked to the base at the top edge and must be removed from the bottom edge first. Use a small Phillips screwdriver to loosen the security screw as shown in Figure 1. Complete removal of the screw is not required. Use the screwdriver to carefully pry each bottom corner if necessary. Tip the cover away from the base and sit it aside as shown in Figure 2.

Sit the PCB aside until the base is mounted on the wall. For added protection, place the PCB in the supplied anti-static bag.

Mount the base by screwing to an electrical box or directly to the wall as shown in Figure 4. The mounting hole locations are shown on page 5.

After the base is screwed to an electrical box or directly to the wall using the appropriate holes, remove the PCB from the anti-static bag, feed connection wires through the center hole and place the top of the PCB into the PCB holders on the backplate and carefully snap the bottom of the PCB into place as shown in Figure 4.

Make wiring connections as per the Wiring Illustrations on page 2 and install the decorative cover by placing the top of the cover into the cover holder on the top of the backplate and snapping the bottom into place as shown in Figure 4. Tighten the security screw with a Phillips screwdriver.

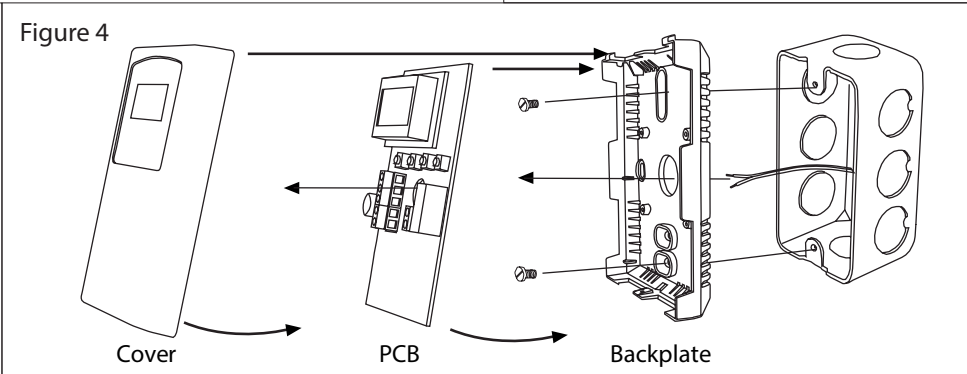
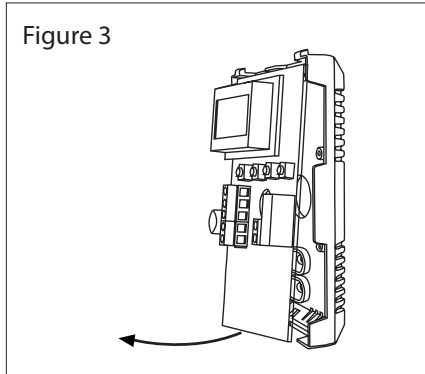
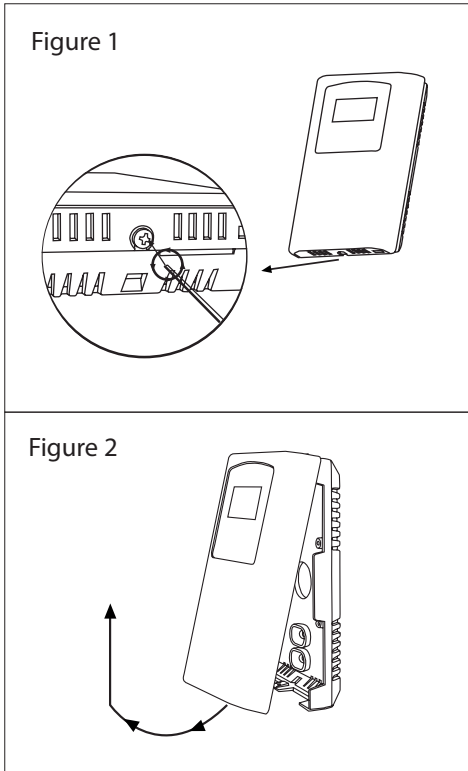

WIRING

Deactivate the 24 Vac/dc power supply until all connections are made to the device to prevent electrical shock or equipment damage. Follow proper electrostatic discharge (ESD) handling procedures when installing the device or equipment damage may occur.

Use 22 AWG shielded wiring for all connections and do not locate the device wires in the same conduit with wiring used to supply inductive loads such as motors. Connect the cable shield to ground at the controller only. Make all connections in accordance with national and local codes.

Connector layout is shown in Figure 5. The diagram shown includes all options. If an option is not ordered, the connector will not be present.

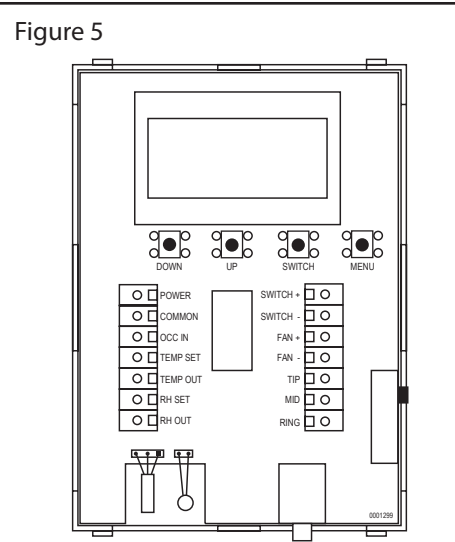
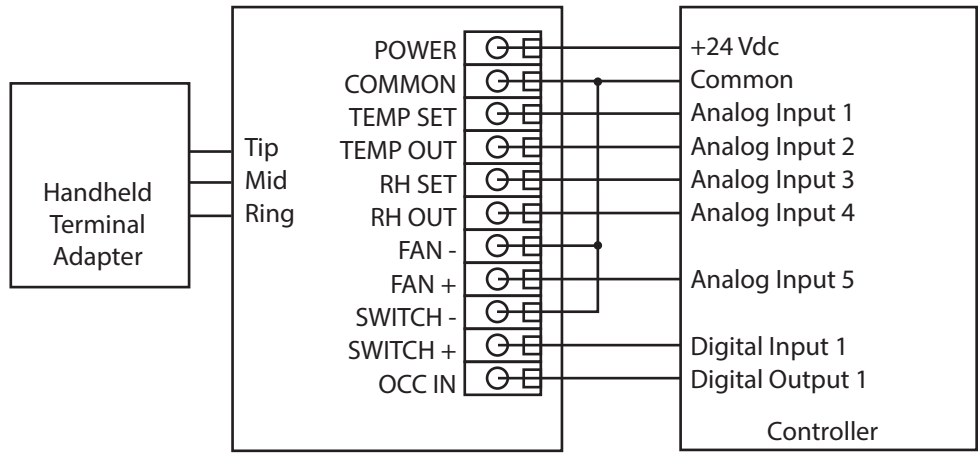

Figure 6



This is a sourcing device and requires from 3 to 14 wires to implement all features. Connect the plus dc or the ac voltage hot side to the POWER terminal. The power supply common is connected to the COMMON terminal. The device is reverse voltage protected and will not operate if connected backwards. It has a half-wave power supply so the supply common is the same as the signal common. Several devices may be connected to one power supply and the output signals all share the same common. Use caution when grounding the secondary of a transformer or when wiring multiple devices to ensure the ground point is the same on all devices and the controller.

The analog outputs are available on the RH OUT, TEMP OUT, TEMP SET, and RH SET terminals. For 4-20 mA output type, all outputs operate in the Active mode and do not require a loop power supply. This means the signal current is generated by the transmitter and must not be connected to a powered input or device damage will result. Check the controller Analog Input to determine the proper connection before applying power. All output signals are referenced to the COMMON terminal. The analog output signals are typically connected directly to the Building Automation System and used as control parameters or for logging purposes.

The device is also available with field-selectable 0-5 or 0-10 Vdc voltage signal outputs which connect directly to a high impedance analog input. In either case the terminal designations are the same and the signals are referenced to COMMON.

The OCC IN terminal is a digital input that controls the OCC segment on the LCD to indicate an occupied condition. It can be connected to a 0-5V digital signal or a dry contact signal. This is usually an active low input signal and requires that the OCC IN terminal be shorted to COMMON to activate the input.

The override switch output is a dry-contact and is available on the SWITCH + and SWITCH - terminals. It is typically connected to a low-voltage digital input on the controller to indicate room occupancy or override when the button is activated.

The resistive fan speed output signal is available on the FAN + and FAN - terminals and has five positions.

The external jack is internally connected to a three-pin terminal block labeled RING, MID, and TIP to accept a stereo phono plug for remote communication with the controller.

START-UP

Verify that the transmitter is properly wired and connections are tight. Apply power and note that the LCD will begin displaying the RH and temperature levels (if configured for both). The display normally toggles between the two values on a 2 second interval. All the output signals will also be available immediately after start-up.

LCD DISPLAY

If the device has both RH and temperature signals, then the multi-function display is factory set to display both measurement values at two second intervals. The RH will be displayed as 0 to 100 %RH for two seconds and then the temperature will be displayed as 0.0 - 35.0°C for two seconds. This cycle will repeat constantly.

If the device is only configured for one parameter, RH or T, then only one parameter will be displayed continuously. The Setup Menu can be used to modify the displayed information. For RH and T devices, the installer can be select to only display RH or temperature continuously. The device supports four temperature ranges that may also be selected in the menu. The default is 0 to 35°C but this may be changed to 32 to 95°F and the output signal will stay the same. Also, the temperature range may be changed to 0 to 50°C or 32 to 122°F and the output signal scaling will change to match the display.

OUTPUTS

The RH output is scaled such that 4-20 mA (or 0-5 or 0-10 Vdc) equals 0 to 100 %RH and is temperature compensated over the full 0 to 50°C temperature range. The temperature output is scaled such that 4-20 mA (or 0-5 or 0-10 Vdc) equals either 0 to 35°C, 32 to 95°F, 0 to 50°C or 32 to 122°F depending on which range is selected in the menu. The factory default range is 0 to 35°C.

In addition, there may also be one or two set-point output signals. These outputs are also 4-20 mA (or 0-5 or 0-10 Vdc). Scaling is determined by parameters set in the Setup Menu. If available, the temperature set-point signal factory defaults to 22 ±5°C. In this case, a set-point equal to 22°C would cause an output signal of 12 mA or 50% of the range (4-20mA). Each step up or down will cause a proportional change in the output to either 20 mA or 4 mA. Both the midpoint and the range can be configured in the menu. The midpoint may be changed from 18 to 27°C or 65 to 80°F and the range can be changed from ±2 to ±10°C or ±5 to ±20°F. This display and output scaling will change to match the selected range.

The following table shows the changes that would result from ±5°C range on the set-point control with a midpoint of 22°C.

	SET-POINT TEMPERATURE	4-20 mA DEVICE	0-5 VDC DEVICE	0-10 VDC DEVICE
-5	17°C	4.0 mA	0.0 Vdc	0 Vdc
-4	18°C	5.6 mA	0.5 Vdc	1 Vdc
-3	19°C	7.2 mA	1.0 Vdc	2 Vdc
-2	20°C	8.8 mA	1.5 Vdc	3 Vdc
-1	21°C	10.4 mA	2.0 Vdc	4 Vdc
Midpoint	22°C	12.0 mA	2.5 Vdc	5 Vdc
+1	23°C	13.6 mA	3.0 Vdc	6 Vdc
+2	24°C	15.2 mA	3.5 Vdc	7 Vdc
+3	25°C	16.8 mA	4.0 Vdc	8 Vdc
+4	26°C	18.4 mA	4.5 Vdc	9 Vdc
+5	27°C	20.0 mA	5.0 Vdc	10 Vdc

The RH set-point operates in a similar manner. The factory default midpoint is 45 %RH and the range is +10 %RH to result in a control of 35 to 55 %RH. The output signal is scaled the same as shown above.

NOTE: All all programmed parameters and the actual set-point values are saved in non-volatile memory so the device will remember the settings after a power-outage.

SET-POINT OPERATION

The device may have 0, 1, or 2 set-point controls. If the device has a set-point control, then the unit will have two buttons labeled UP and DOWN for set-point adjustment. During normal operation, the LCD displays either RH, T, or both depending on the hardware configuration and program settings. When either the UP or DOWN buttons are pressed the display will change to set-point mode (indicated by a flashing display). The display will show the previous set-point setting such as 22.0°C or 72.0°F for temperature set-point or 45 %RH for humidity set-point. If no other action is taken for 5 seconds then the device will reset to normal operation. While the display is still flashing, the set-point can be modified by pressing the UP or DOWN buttons to increase or decrease the set-point value. The LCD will update

to show the new set-point and the output signal will update accordingly. When the desired set-point is shown on the LCD, leave the unit for 5 seconds to reset to normal operation and save the new setting. Note that the set-point can only be set around the programmed midpoint and within the programmed range as set in the menu.

If the device has two set-point controls, for both RH and T, then the UP and DOWN buttons have two functions. Operation is the same as described above except the device will show the main (default is temperature) set-point first when either UP or DOWN is pressed. The main set-point may be modified at this time by using the UP or DOWN buttons as before. To access the secondary (default is RH) set-point, press and hold either the UP or DOWN buttons for 5 seconds and the device will enter the secondary set-point mode. Then the second set-point may be modified with the UP or DOWN buttons. All set-point changes are saved on exit after 5 seconds. The main and secondary set-points can be assigned in the menu.

SET-UP MENU

The menu has several items as shown below and the device cover must be removed to access the menu. To enter the menu, press and release the <MENU> key while in normal operation. This will enter the Setup Menu, pressing the <MENU> key a second time saves any changes and advances to the next menu item. The <UP> and <DOWN> keys are used to make changes to program variables by scrolling through the available options.

Setup Menu operation is explained below, the factory default values are shown. Note that items that are not applicable to the hardware configuration are skipped on the device's setup.

Press and release the <MENU> key while in normal operation.

1. CELSIUS/FAHRENHEIT



The temperature scale defaults to Celsius (°C). It can be changed to Fahrenheit (°F) by using the <UP> or <DOWN> keys. This item is not shown for RH + RH set-point models.

<MENU> Press to advance to next menu item

2. TEMPERATURE RANGE



The available temperature ranges are 0 to 35°C (32 to 95°F) or 0 to 50°C (32 to 122°F). Use the <UP> and <DOWN> keys to select the appropriate range.

<MENU> Press to advance to next menu item

3. TEMPERATURE OFFSET



Use <UP> or <DOWN> to add or subtract an offset to the temperature output signal and display. The default is 0 but can be changed from -9 to +9°F for temperature calibration.

<MENU> Press to advance to next menu item

4. TEMPERATURE SET-POINT MIDPOINT



The default temperature set-point midpoint is 22 for °C or 72 for °F. This can be changed using <UP> or <DOWN> to 18 to 27°C or 65 to 80°F.

<MENU> Press to advance to next menu item

5. TEMPERATURE SET-POINT RANGE



The default temperature set-point range is ±5 for °C and ±10 for °F. This can be changed using <UP> or <DOWN> to ±2 to ±10 for °C or ±5 to ±20 for °F.

<MENU> Press to advance to next menu item

6. TEMPERATURE SET-POINT RESOLUTION



The default temperature set-point resolution is 1.0°C or 1.0°F. This can be changed using <UP> or <DOWN> to 0.5°C or 2.0°F.

<MENU> Press to advance to next menu item

7. RH OFFSET



Use <UP> or <DOWN> to add or subtract an offset to the RH output signal and display. The default is 0 but can be changed from -20 to +20 %RH for humidity calibration.

<MENU> Press to advance to next menu item

8. RH SET-POINT MIDPOINT



The default RH set-point midpoint is 45 %RH. This can be changed using <UP> or <DOWN> from 20 to 70 %RH.

<MENU> Press to advance to next menu item

9. RH SET-POINT RANGE



The default RH set-point range is ± 10 %RH. This can be changed using <UP> or <DOWN> to ± 5 or ± 20 %RH.

<MENU> Press to advance to next menu item

10. DISPLAY MODE



Select parameters to display on the LCD. 1 = Temperature only, 2 = RH only and 3 = T + RH alternately every 2 seconds. Use <UP> and <DOWN> to change. Default is 3 for RH and T.

<MENU> Press to advance to next menu item

11. DEFAULT SET-POINT



Default is 0 for main set-point = Temperature, secondary setpoint=RH. Change with <UP> or <DOWN> to 1 to reverse the two setpoints. This only applies to models with two setpoints.

<MENU> Press to advance to next menu item

12. OUTPUT SIGNAL



Default is 5 for 0-5 Vdc output signal. Can change with <UP> or <DOWN> to 10 for 0-10 Vdc outputs.

<MENU> Press to advance to next menu item

13. OCC REVERSE

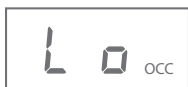

The default OCC signal type is active low (Lo). Can change with <UP> or <DOWN> to active high (HI) to reverse the OCC action. By default, shorting the OCC input to common will turn on the OCC LCD segment.

<MENU> Press to advance to next menu item

14. BACKLIGHT ENABLE



Use the <UP> or <DOWN> keys to enable or disable the LCD backlight. bL1 = backlight on, bL0 = backlight off.

<MENU> Press to exit the set-up menu and return to normal operation

DIMENSIONS

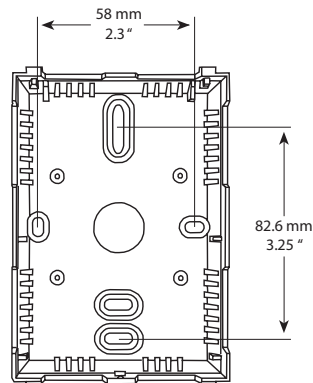
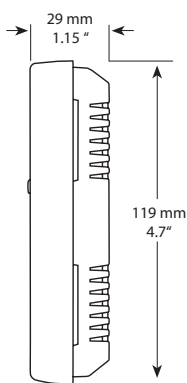
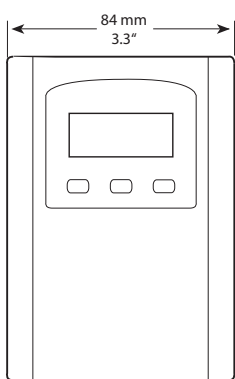

SPECIFICATIONS

TEMPERATURE SENSOR

Type..... 10K Ω Type 7 curve matched thermistor
Accuracy $\pm 0.2^{\circ}\text{C}$ ($\pm 0.4^{\circ}\text{F}$)
Range..... 0 to 35°C (32 to 95°F) or 0 to 50°C (32 to 122°F) programmable
Offset $\pm 9^{\circ}\text{F}$ programmable
Display Units $^{\circ}\text{C}$ or $^{\circ}\text{F}$ programmable
Display Resolution $0.5^{\circ} < 100^{\circ}$, $1^{\circ} > 100^{\circ}$

HUMIDITY SENSOR

Type Thermoset polymer based capacitive
Accuracy $\pm 2\% \text{RH}$
Range..... 0 to 100 %RH
Temperature Compensation 0 to 50°C (32 to 122°F)
Hysteresis $\pm 1.5\% \text{RH}$
Response Time 15 seconds typical
Stability $\pm 1.2\% \text{RH}$ typical @ 50 %RH in 5 years
Offset $\pm 20\% \text{RH}$ programmable

TEMPERATURE SET-POINT

Midpoint..... 18 to 27°C (65 to 80°F) programmable
Range..... ± 2 to $\pm 10^{\circ}\text{C}$ (± 5 to $\pm 20^{\circ}\text{F}$) of the midpoint programmable
Resolution..... 0.5 or 1.0°C and 1.0 or 2.0°F programmable

RH SET-POINT

Midpoint..... 20 to 70 %RH programmable
Range..... ± 5 , ± 10 or $\pm 20\% \text{RH}$ of the midpoint programmable
Resolution..... 1 %RH

OVERRIDE

Type..... Front panel push-button available as dry-contact 2 wire output
Front Panel Push-Button..... N.O., 50 mA @ 12 Vdc

COMMUNICATION

3.5mm Phono Jack..... Connects to 3 pin terminal block (Ring, Tip, Mid)

FAN SPEED SWITCH

Range..... Off, Auto, Low, Medium, High
Signal 0, 2, 4, 6, and 8K standard, 2 wire output (other values available)

OCCUPIED INPUT

Signal Type..... Digital input, 0-5 Vdc or dry contact to common
Logic..... Active low or active high programmable
Action Causes "OCC" segment to light on LCD

LCD DISPLAY

Display Size..... 38.1mm W x 16.5mm H (1.5" x 0.65")
Digit Height 11.43mm (0.45")
Symbols $^{\circ}\text{C}$, $^{\circ}\text{F}$, %RH, OCC
Backlight..... Enable or disable via menu

GENERAL

Power Supply..... 24 Vac/dc $\pm 10\%$ (non-isolated half-wave rectified)
Consumption..... 20 mA + (20 mA x number of outputs) max @ 24 Vdc
Input Voltage Effect Negligible over specified operating range
Protection Circuitry..... Reverse voltage and MOV protected, output limited
Output Signals 4-20 mA active (sourcing) or 0-5/0-10 Vdc
Output Resolution..... 10 bit for all signals
Output Drive Capability..... **Current:** 550 Ω max
Voltage: 10 K Ω min
Programming and Selection Via push-buttons and on-screen menu
Operating Conditions 0 to 50°C (32 to 122°F), 5 to 95 %RH non-condensing
Wiring Connections..... Screw terminal block (14 to 22 AWG)
Enclosure White ABS, IP30 (NEMA 1)
84mm W x 117mm H x 29mm D (3.3" x 4.6" x 1.15")
Country of Origin..... Canada