

INTRODUCTION

The Carbon Monoxide Transmitter uses an electrochemical sensor to monitor the CO level and outputs a proportional 0-10 Vdc signal. The device may also be configured with an alarm relay.

BEFORE INSTALLATION

Read these instructions carefully before installing and commissioning the CO transmitter. Failure to follow these instructions may result in product damage. Do not use in an explosive or hazardous environment, with combustible or flammable gases, as a safety or emergency stop device or in any other application where failure of the product could result in personal injury. **Take electrostatic discharge precautions during installation and do not exceed the device ratings.**

MOUNTING

The transmitter should be mounted on a flat surface three to five feet from the floor of the area to be controlled. Do not mount the sensor near doors, opening windows, supply air diffusers, or other known air disturbances. Avoid areas with vibrations or rapid temperature changes.

The transmitter has two integrated mounting tabs on either side of the enclosure that facilitate a #10 size screw (not supplied). See Figure 1.

Remove the cover from the enclosure by loosening 4 Phillips screws in each corner of the enclosure as seen in Figure 2.

Complete wiring instructions on page 2. Re-install the cover and tighten the screws with a Phillips screwdriver. See Figure 3.

Figure 1

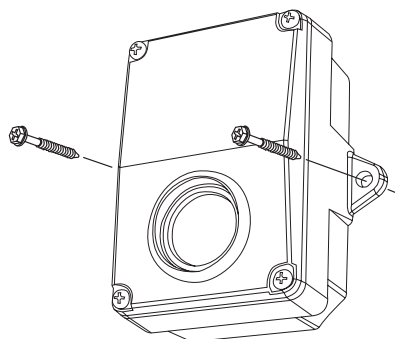

Figure 2

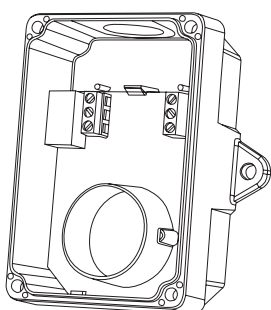
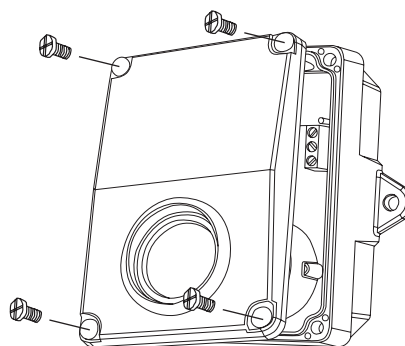

Figure 3



WIRING

Use 22 AWG shielded wire for all connections and do not locate the device wires in the same conduit with wiring used to supply inductive loads such as motors. Disconnect the power supply before making any connections to prevent electrical shock or equipment damage. Make all connections in accordance with national and local codes.

Connect either an AC or DC power supply to POWER and COMMON and the 0-10 Vdc signal is available on the OUTPUT terminal with respect to COMMON as shown in Figure 4. The device is reverse voltage protected and will not operate if the power supply is connected backwards.

Ensure the controller Analog Input (AI) matches the transmitter output signal type before power is applied. The output signal has a minimum load that it will drive, follow the ratings in the Specification section or inaccurate readings may result.

If equipped, the relay output is available on the NO, NC and R.COM terminals. The relay R.COM terminal is NOT connected to the signal or power supply COMMON terminal. The relay output is completely isolated and has both Normally Open (NO) and Normally Closed (NC) signals. These signals can be used to directly control alarms, ventilation fans or may be connected to digital inputs of the B.A.S. for status monitoring.

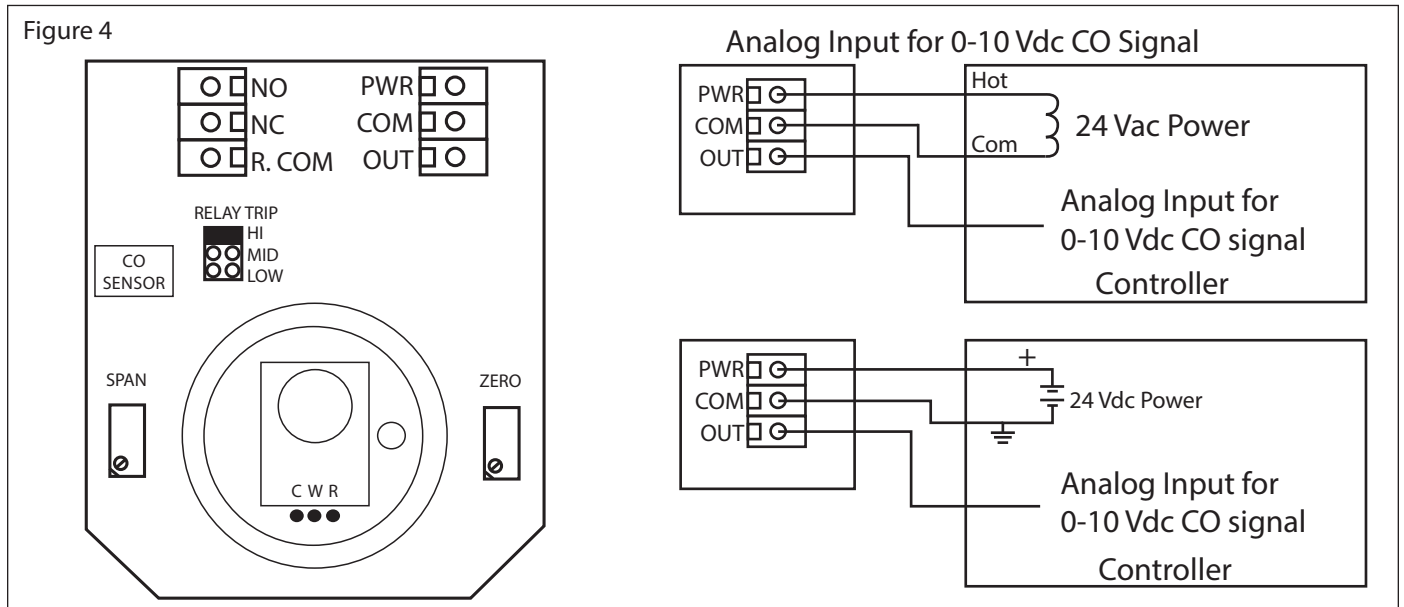

OPERATION

In normal operation the sensor will measure the CO level in the surrounding air and output a proportional value on the 0-10 Vdc output. The CO measurement range is 0-300 ppm. An optional relay can be used to indicate an alarm condition. The trip point for the relay can be programmed to three different settings with an on-board jumper as shown in Figure 5. If the CO level exceeds the trip point then the relay is activated. The relay will remain activated until the CO level drops below the (trip level – hysteresis) where hysteresis is 3% or 9 ppm.

Figure 5

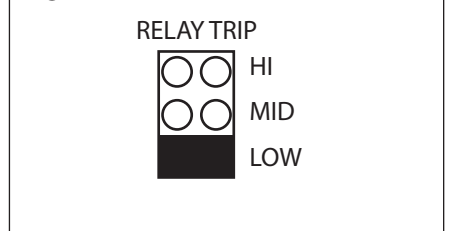

START-UP

Verify that the Carbon Monoxide Transmitter is properly wired according to the wiring diagrams and all connections are tight. Apply power to the device and the sensor will begin reading the CO level and output the analog signal.

CALIBRATION

The transmitter features a simple snap-mount sensor pcb that is pre-calibrated. This means that the entire sensor pcb can simply be replaced with a new calibrated pcb if desired without having to remove the enclosure. This sensor swap requires no tools and can be completed in seconds. Simply disconnect the device wiring, remove the old sensor pcb, snap in the new pcb and reconnect the device power. There is no need to make any adjustments or apply gas to the transmitter using the sensor swap method.

The device may also be calibrated or verified with CO gas if required. This requires a field calibration kit consisting of a bottle of gas (250 ppm CO in air for example), a tank pressure regulator with flow restrictor and the necessary tubing with a calibration cap to cover to the sensor. Calibration can be done at 20-27 °C (68-81°F).

Verification with gas can be done without removing the device cover. Simply apply gas using the calibration cap attached directly to the port on the cover as shown in Figure 6 and monitor the output signal.

The device cover must be removed to perform an actual calibration. In this case, the gas calibration cap attaches to the sensor fixture inside the enclosure as shown in Figure 7. The sensor must be continuously powered for at least 1/2 hour prior to calibration. Calibrate the sensor first in clean air with no CO gas present. Simply adjust the ZERO pot on the sensor board until a 0 Vdc output is obtained. For this case, adjust the output slightly above 0 Vdc and then slowly reduce the output signal to 0 Vdc. The output signal may be monitored with a voltmeter connected to the OUTPUT and COMMON terminals.

Then attach the gas supply. Turn the regulator on/off knob fully off and attach it to the 250 ppm gas bottle and firmly tighten it by hand. Moisten the sponge and squeeze out any excess water. Place the sponge in the cap so that it will not touch the sensor but does not plug the hole in the side of the cap. Attach the cap to the fixture over the sensor. Slowly turn the valve knob on the regulator to let the gas begin flowing.

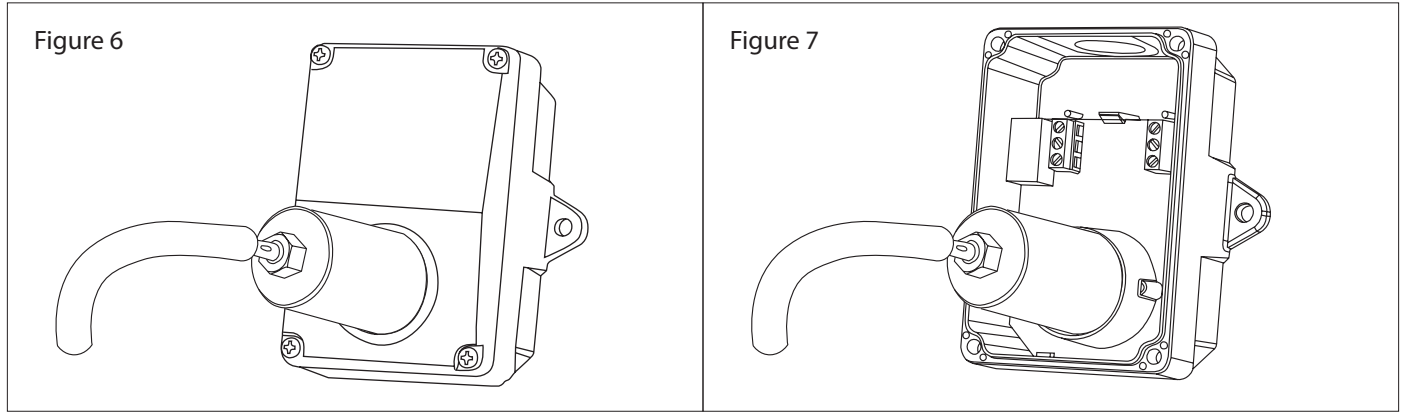

The regulator will restrict the flow rate to the specified 200 ml/min and the sponge will ensure the gas is in the right humidity range. Wait for 5 minutes and then adjust the SPAN pot on the sensor board until the output reads 250 ppm. For the 0-300 ppm device span, 250 ppm would equal 8.33 Vdc. Close the valve on the tank and take the cap off from the sensor. Calibration is complete.

If the gas cap is too loose on the fixtures, simply place a wrap of electrical tape around the cap to tighten it.

DIMENSIONS

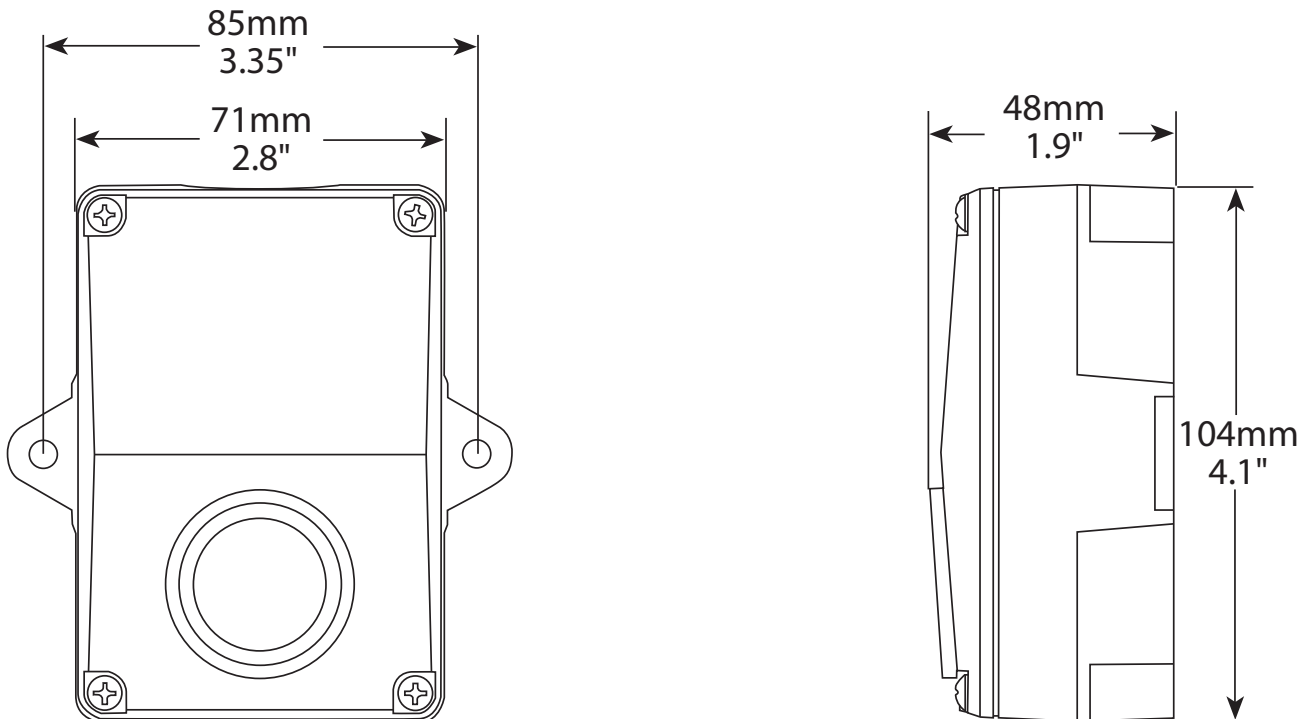

SPECIFICATIONS

GENERAL

Measurement.....	Electrochemical
Sample Method	Diffusion
Measurement Range.....	0 to 300 ppm
Accuracy	±5 ppm or ±5% of reading (whichever is greater) 0 to 50°C (32 to 122°F), 15 to 90 %RH
Agency Approvals	Sensor is UL recognized for ANSI/UL-2034 and UL-2075, E240671
Operating Conditions	-20 to 50°C (-4 to 122°F), 15 to 90 %RH, 0.9 - 1.1 atm
Stability	<5% signal loss/year
Response Time	<35 seconds for 90% step change
Life Expectancy	7 years
Typical Area Coverage	700 m ² (7500 ft ²) or 15m (50ft) radius
Power Supply	24 Vdc ±20% or 24 Vac ±10% (non-isolated half-wave rectified)
Consumption	Relay Model: 40 mA max Non-relay Model: 20 mA max
Output Signal.....	0-10 Vdc
Output Drive Capability	10K Ω min
Optional Relay Contacts	Form C contacts (N.O. and N.C.), 5 Amps @ 250 Vac, 5 Amps @ 30 Vdc
Relay Trip Point.....	25, 60 or 150 ppm jumper selectable
Relay Hysteresis.....	3% or 9 ppm
Wiring Connections.....	Screw terminal block (14 to 22 AWG)
Enclosure	Polycarbonate or ABS, UL94-V0, IP65 (NEMA 4X) 71mm W x 104mm H x 48mm D (2.8" x 4.1" x 1.9")
Country of Origin.....	Canada