

INTRODUCTION

The CO2 transmitter uses Infrared Technology to monitor CO2 levels and outputs a linear 4-20 mA or 0-5/0-10 Vdc signal. Options include a control relay and a resistive temperature sensor. Features include a back-lit LCD and a user menu for easy installation.

BEFORE INSTALLATION

Read these instructions carefully before installing and commissioning the transmitter. Failure to follow these instructions may result in product damage. Do not use in an explosive or hazardous environment, with combustible or flammable gases, as a safety or emergency stop device or in any other application where failure of the product could result in personal injury. **Take electrostatic discharge precautions**

during installation and do not exceed the device ratings.

MOUNTING

Mount the sensor in an easily accessible location in a straight section of duct at least five feet from corners or other items that may cause disturbances in the air flow. Avoid areas where the detector is exposed to vibrations or rapid temperature changes.

The principal of operation is based on the Venturi effect of the probe that extends into the HVAC duct. Air flowing through the duct is forced into the vent holes on one side of the probe, into the enclosure, over the CO2 sensor and then the air is drawn back out of the enclosure via the vent holes on the opposite side of the probe.

Drill or punch a 7/8" or 1" hole in the duct at the preferred location and insert the probe into the hole to mark the enclosure mounting holes. Remove the unit and drill the two mounting holes. Clean all drilled holes of debris before mounting the device. Mount the enclosure to the duct with two sheet metal screws such that the duct air flow is parallel with the vent holes in the probe (i.e.: air flows directly into the probe holes). To prevent air leaks, ensure the gasket is compressed around the probe between the device enclosure and the air duct.

The enclosure has a hinged cover with a latch. Open the cover by pulling slightly on the latch on the bottom of the enclosure, at the same time pulling on the cover, as illustrated in Figure 2.

A 1/2" NPT threaded connection hole is provided in the left side of the enclosure. Screw the EMT connector or cable gland connector in until tight. See Figure 3. It is recommended that weatherproof conduit or cable gland fittings be used. The F style enclosure includes a 1/2" NPT to M16 thread adapter and cable gland fitting.

Make wiring connections as per the "Wiring" illustrations on Page 2.

Swing door closed until securely latched. For added security, 2 screws are provided that may be installed in the integrated screw tabs. See Figure 4.

Figure 1

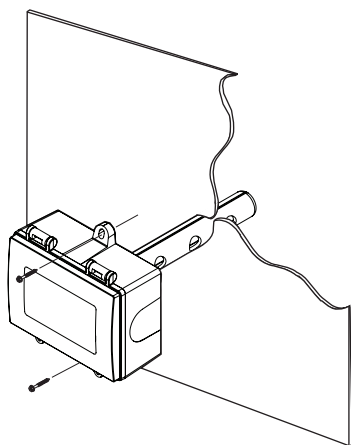

Figure 2

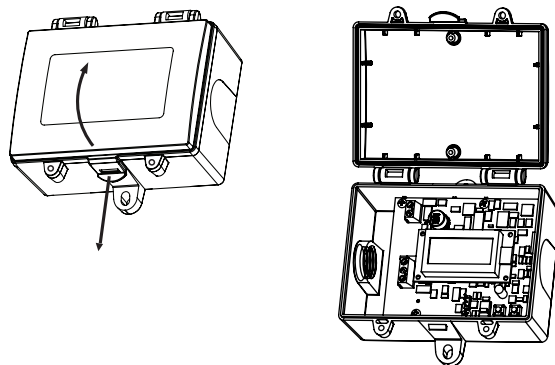

Figure 3

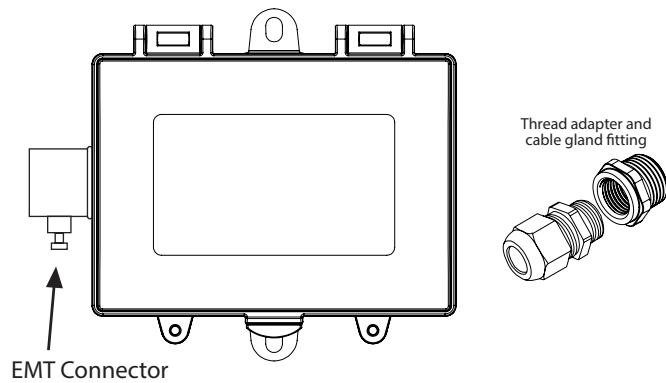
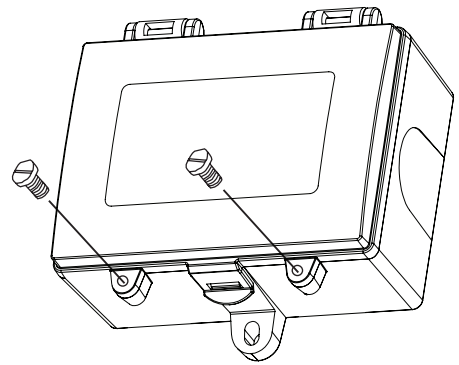

Figure 4



WIRING

- Deactivate the 24 Vac/dc power supply until all connections are made to the device to prevent electrical shock or equipment damage. Follow proper electrostatic discharge (ESD) handling procedures when installing the device or equipment damage may occur.
- Use 22 AWG shielded wiring for all connections and do not locate the device wires in the same conduit with wiring used to supply inductive loads such as motors. Make all connections in accordance with national and local codes.
- Connect the plus dc or the ac voltage hot side to the POWER terminal.
- The supply common is connected to the COMMON terminal.
- The device is reverse voltage protected and will not operate if connected backwards. It has a half-wave power supply so the supply common is the same as the signal common.
- Several devices may be connected to one power supply and the output signals all share the same common. Use caution when grounding the secondary of a transformer or when wiring multiple devices to ensure the ground point is the same on all devices and the controller.
- The analog output is available on the CO2 terminal. This signal is jumper selectable for either voltage or 4-20 mA active output. In voltage mode the output is selectable for either 0-5 or 0-10 Vdc via the menu (the factory default is 0-5 Vdc). The current output operates in the active mode and does not require a loop power supply. This means that the signal current is generated by the transmitter and must not be connected to a powered input or device damage will result.
- Check the controller Analog Input to determine the proper connection before applying power. Both current and voltage signals are referenced to the COMMON terminal. The analog output signal is typically connected directly to the Building Automation System (B.A.S.) and used as a control parameter or for logging purposes.
- An optional signal is the relay output available on the N.O. RELAY terminals. The relay output is completely isolated and has a Normally Open (NO) signal. This signal can be used to directly control an alarm or ventilation fan.
- The two-wire resistive temperature sensor output signal can be ordered with various RTDs and thermistors to suit all control applications and is available on the TEMP and TEMP A terminals.

NOTE: The N.O. RELAY terminal is optional and may or may not be on the device

Figure 5

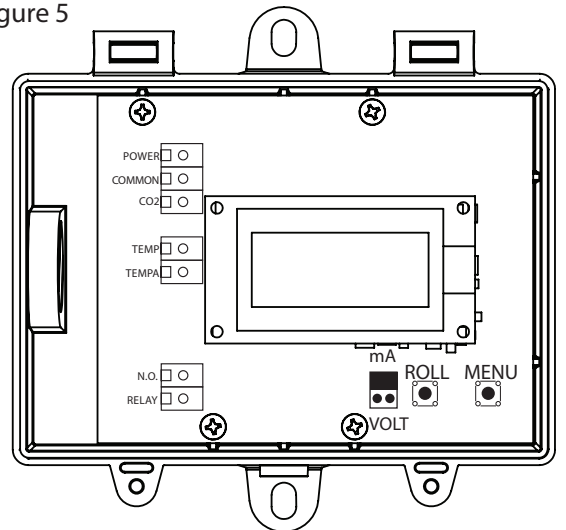
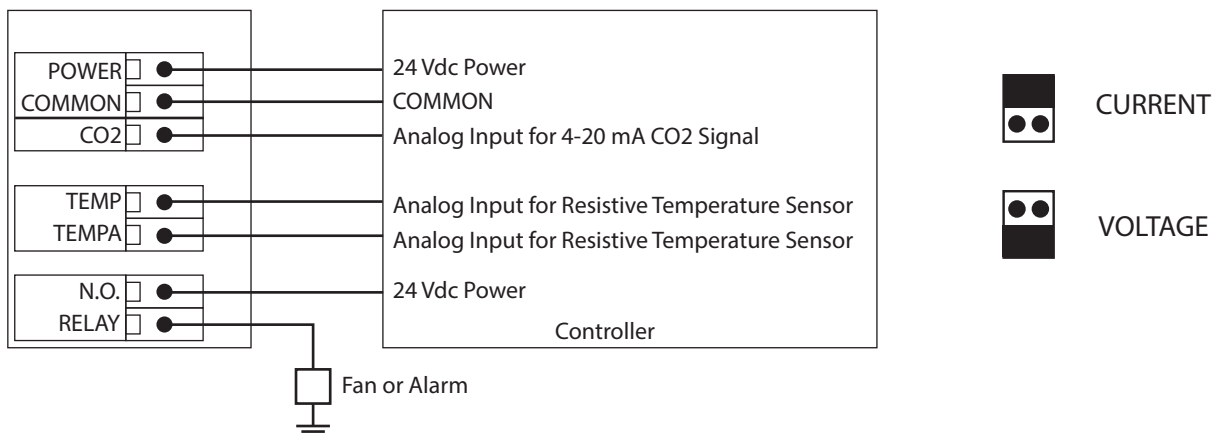

Figure 6

Typical 4-20 mA wiring with 24 Vdc and all options



OUTPUTS

The CO2 output is scaled so that 4-20 mA (or 0-5/0-10Vdc) equals 0 to Out_High as set in the user menu. Depending on the model ordered, the factory default is either 0-2000 ppm or 0-20,000 ppm. The Out_High can be changed in the user menu and the output signal is scaled accordingly. For voltage output models, the factory default is 0-5 Vdc and can be changed to 0-10 Vdc in the user menu.

OPERATION

The CO2 signal is connected to the BAS analog input. The BAS reads the voltage or current signals and calculates actual values using correct scaling for the ranges and signal type. These values can be used to control ventilation devices or initiate alarms. All values are displayed locally on the LCD. The CO2 level will be displayed as 0-2000 ppm or 0-20,000 ppm depending on the model.

If the optional relay is installed it can directly control a small fan or alarm by setting the trip value and hysteresis to appropriate values. The relay status is not indicated on the device LCD.

USER MENU

The User Menu has several items as shown below. To enter the menu, press and release the <MENU> key while in normal operation. This will enter the User Menu step 1, pressing the <MENU> key a second time advances to step 2. Each press of the <MENU> key saves the selection and advances the menu item. The <ROLL> key is used to make changes to program variables by scrolling through the available options.

NOTE: If no keys are pressed for 5 minutes, the menu will automatically exit.

<MENU> Press and release to enter the setup menu.

*Out High
2000 ppm*

For single channel NDIR CO2 model only. The default CO2 range is 0-2000 ppm. The output span can be changed from 1000 to 7500 ppm in increments of 500. Use <ROLL> to change the value.

*Out High
20000 ppm*

For dual channel NDIR CO2 model only. Default CO2 range is 0-20,000 ppm. The output span can be changed from 2000 to 20,000 ppm in increments of 500. Use <ROLL> to change the value.

<MENU> Press to advance to next menu item

*Altitude
0 ft*

The default is 0 feet. Change by using <ROLL> from 0 to 5000 feet in 500 foot increments for CO2 local altitude correction.

<MENU> Press to advance to next menu item

*Auto Cal
ON*

For single channel NDIR CO2 model only. Automatic Cal Mode default is ON to correct CO₂ sensor drift to better than ±10 ppm per year. ON is recommended for applications where the CO₂ level will be close to normal (400 ppm) at least once per day. If a building is occupied 24 hours and the CO₂ level is fairly constant then the dual beam sensor should be used.

<MENU> Press to advance to next menu item

For models with the relay option installed

*Relay SP
1000 ppm*

The relay trip setpoint default is 1000 ppm. Use <ROLL> to change from 500 to 5000 for single channel NDIR CO2 model in 100 ppm increments or from 500 to 15,000 for dual channel NDIR CO2 model in 100 ppm increments.

<MENU> Press to advance to next menu item

*Relay Hy
50 ppm*

The relay hysteresis default is 50 ppm. Use <ROLL> to change from 25 to 200 for single channel NDIR CO2 model or from 25 to 500 for dual channel NDIR CO2 model in 25 ppm increments.

<MENU> Press to advance to next menu item

Relay
On Delay

The relay on delay time default is 15 seconds. Use <ROLL> to change from 0 to 255 seconds in 1 second increments.

<MENU>

Press to advance to next menu item

Relay
Test OFF

Use <ROLL> to toggle the relay ON or OFF for testing purposes.

<MENU>

Press to advance to next menu item

For models with the voltage output only

Out Type
0-5 Vdc

The default output type is 0-5 Vdc. Use <ROLL> to change to 0-10 Vdc if necessary.

<MENU>

Press to advance to next menu item

Calibrat
0 ppm

For dual channel NDIR CO2 model only. This item is used for 0 ppm gas calibration and is explained in the *Calibration* section.

<MENU>

Press to advance to next menu item

Calibrat
1000 ppm

This item is used for 1000 ppm gas calibration and is explained in the *Calibration* section.

<MENU>

Press to advance to next menu item

Calibrat
20000 ppm

For dual channel NDIR CO2 model only. This item is used for 20,000 ppm gas calibration and is explained in the *Calibration* section.

<MENU>

Press to advance to next menu item

BackLite
Auto

Use <ROLL> to enable, disable, or set to auto the LCD backlight. When enabled the LCD backlight is always on, when disabled it never lights and if set to auto it lights for a time period of 30 seconds whenever a key is pressed. The factory default is Auto.

<MENU>

Press to exit the menu and return to normal operation.

Menu
Exit

Press <MENU> or <ROLL> to exit the menu and return to normal operation.

CALIBRATION

CO2 calibration with gas requires a field calibration kit with pressure regulator, necessary tubing and appropriate bottles of CO2 gas. Note that the procedure depends on the device model.

SINGLE CHANNEL CALIBRATION

The single channel model requires only a single point 1000 ppm calibration to meet specified accuracy due to the Automatic Calibration mode and other technology incorporated into the model.

1000 PPM CALIBRATION

Turn the regulator knob off and connect the 1000 ppm CO2 gas bottle and hand tighten. Open the cover of the unit to be calibrated to expose the gas sensor Port. Remove the plastic cap on the PCB and connect the tubing from the gas bottle. Turn the regulator knob on to allow gas to flow to the sensor. The CO2 reading on the LCD will begin to approach 1000 ppm. Wait 1 to 2 minutes until the CO2 reading stabilizes.

Enter the user menu and use the <MENU> key to advance to Calibrat 1000 PPM. Press and hold the <SAVE> key for 2 seconds and the display will change to Waiting Calibrat then to Waiting 5 minute to indicate that the device is calibrating. This process takes about 5 minutes. When calibration is complete the unit will display the ppm value and Cal Done. Press the <SAVE> key to return to normal operation and shut the gas off.

Disconnect the tubing and replace the cap on the sensor gas port as calibration is complete.

DUAL CHANNEL CALIBRATION

The dual-channel sensor with extended range requires a 3-point calibration with 0, 1000 and 20,000 ppm gas (in order).

0 PPM CALIBRATION

Turn the regulator knob off and attach it to the Nitrogen gas bottle and hand tighten. Open the cover of the unit to be calibrated to expose the gas sensor port. Remove the plastic cap on the PCB and connect the tubing from the gas bottle. Turn the regulator knob on to allow the gas to flow to the sensor.

Enter the user menu and use the <MENU> key to advance to Calibrat 0 PPM. Press and hold the <SAVE> key for 2 seconds and the display will change to Waiting Calibrat then to Waiting 5 minute to indicate that the process of setting the internal calibration is taking place.

This takes about 5 minutes while the LCD counts down. Do not disturb the unit or the gas flow. When complete the unit will display the ppm value and Cal Done. Press <SAVE> to resume normal operation and shut the gas off.

1000 PPM CALIBRATION

Connect the 1000 ppm CO2 gas bottle and apply the gas as before. The CO2 reading on the LCD will begin to approach 1000 ppm. Wait 1 to 2 minutes until the CO2 reading stabilizes.

Enter the user menu and use the <MENU> key to advance to Calibrat 1000 PPM. Press and hold the <SAVE> key for 2 seconds and the display will change to Waiting Calibrat then to Waiting 5 minute to indicate that the device is calibrating. Again, this process takes about 5 minutes. When calibration is complete the unit will display the ppm value and Cal Done. Press the <SAVE> key to return to normal operation and shut the gas off.

20,000 PPM CALIBRATION

Connect the 20,000 ppm CO2 and apply the gas as before. The LCD will begin to approach 20,000 ppm. Wait 1 to 2 minutes until the CO2 reading stabilizes.

Enter the user menu and use the <MENU> key to advance to Calibrat 20,000 PPM. Press and hold the <SAVE> key for 2 seconds and the display will change to Waiting Calibrat then to Waiting 5 minute.

Again, wait 5 minute and when calibration is complete the unit will display the ppm value and Cal Done. Press <SAVE> to resume normal operation and shut the gas off.

Disconnect the tubing and replace the cap on the sensor gas port as calibration is complete.

