

INTRODUCTION

The space CO₂ sensor series uses a highly accurate and reliable non-dispersive infrared (NDIR) sensor in an attractive, low-profile enclosure to monitor ambient CO₂ levels for room applications. The compact dual channel CO₂ sensor achieves excellent performance characteristics, including high accuracy and low power consumption to ensure stable long term operation. The space CO₂ sensor features both 4-20 mA and voltage outputs (0-5 / 0-10 Vdc) for simple integration into any building automation system for the improvement of energy savings and to assure good indoor air quality. The device is also available with an optional resistive temperature sensor.

BEFORE INSTALLATION

Read these instructions carefully before installing and commissioning the device. Failure to follow these instructions may result in product damage. Do not use in an explosive or hazardous environment, with combustible or flammable gases, as a safety or emergency stop device or in any other application where failure of the product could result in personal injury. **Take electrostatic discharge precautions during installation and do not exceed the device ratings.**

NOTE: This CO₂ sensor incorporates a Self Calibration feature to correct CO₂ sensor drift. This CO₂ sensor is recommended for applications where the CO₂ level will be close to normal (400 ppm) at least one hour per day. If the monitored space is occupied 24 hours or consistently maintains higher levels of CO₂ level, the CD Series is recommended.

MOUNTING

The CO₂ transmitter installs directly on a standard electrical box and should be mounted five feet from the floor of the area to be controlled. **Do not mount the sensor near doors, opening windows, supply air diffusers or other known air disturbances. Avoid areas where the detector is exposed to vibrations or rapid temperature changes.**

The cover is hooked to the base at the top edge and must be removed from the bottom edge first. Use a small Phillips screwdriver to loosen the security screw as shown in Figure 1. (Complete removal of this screw is not required). Use the screwdriver to carefully pry each bottom corner if necessary. Tip the cover away from the base and sit it aside as shown in Figure 2.

Follow usual anti-static procedures when handling the PCB and be careful not to touch the sensors.

Mount the base by screwing to an electrical box or directly to the wall as shown in Figure 4. The mounting hole locations are shown on page 2.

Make wire connections as per the Wiring illustrations on Page 2 and install decorative cover by placing the top of the cover into the cover holder on the top of the backplate and snapping the bottom into place as shown in Figure 4. Tighten security screw with a Phillips screwdriver.

Figure 1

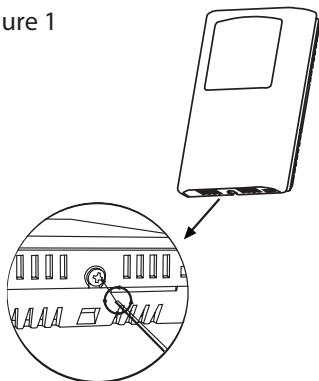

Figure 2

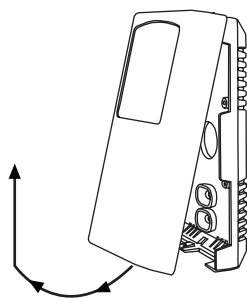
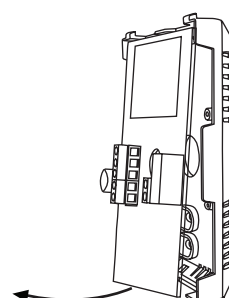
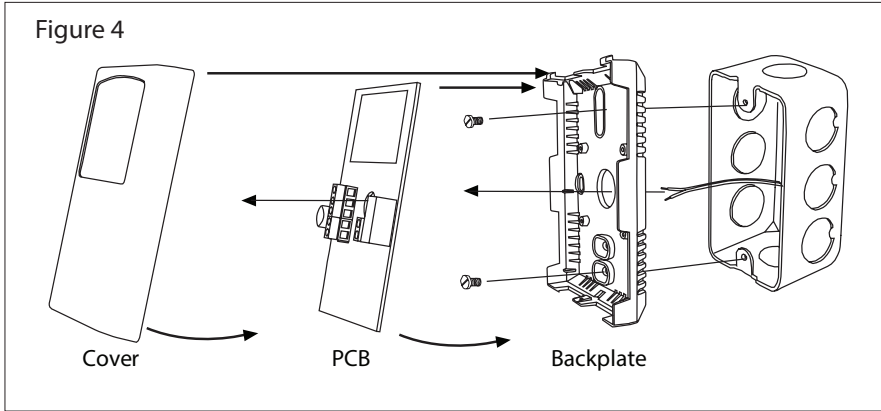

Figure 3



WIRING

Deactivate the 24 Vac/dc power supply until all connections are made to the device to prevent electrical shock or equipment damage. Follow proper electrostatic discharge (ESD) handling procedures when installing the device or equipment damage may occur. Use 22 AWG shielded wiring for all connections and do not locate the device wires in the same conduit with wiring used to supply inductive loads such as motors. Make all connections in accordance with national and local codes.



This is a 3-wire sourcing device. Connect the plus dc or the ac voltage hot side to the POWER terminal. The supply common is connected to the COMMON terminal. The device is reverse voltage protected and will not operate if connected backwards. It has a half-wave power supply so the supply common is the same as the signal common. Several devices may be connected to one power supply and the output signals all share the same common. Use caution when grounding the secondary of a transformer or when wiring multiple devices to ensure the ground point is the same on all devices and the controller.

The analog output is available on one of the CO₂ terminals. Either the mA or VOLT output terminal may be used (but not both at the same time). This signal is used for either voltage or 4-20 mA active output as shown in Figure 5. In voltage mode the output is selectable for either 0-5 or 0-10 Vdc using the PCB jumper. The current output operates in the active mode and does not require a loop power supply (the signal current is generated by the transmitter and must not be connected to a powered input or device damage will result).

Check the controller Analog Input to determine the proper connection before applying power. Both current and voltage signals are referenced to the COMMON terminal. The analog output signal is typically connected directly to the Building Automation System (B.A.S.) and used as a control parameter or for logging purposes.

The two-wire temperature sensor output is available with various RTDs and thermistors to suit all control applications and is available on the TEMP SENSOR terminals as shown in Figure 5.

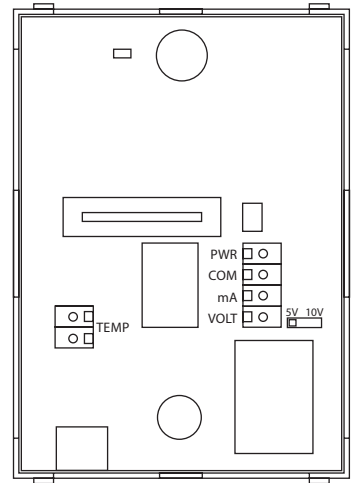
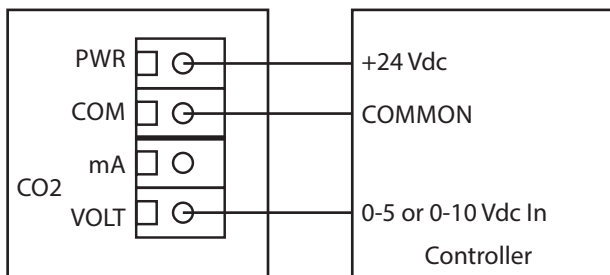
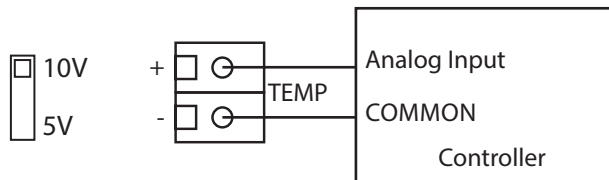
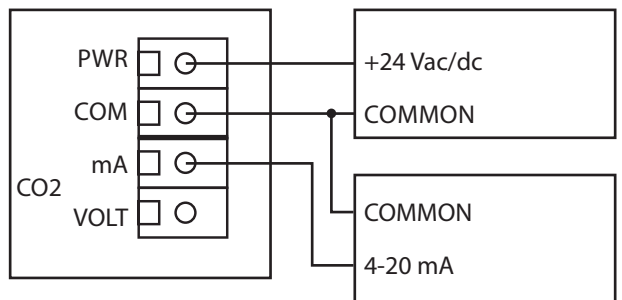

Figure 5

Wiring for voltage output signal and 24 Vdc power from controller



Wiring for 4-20 mA output and external 24 Vac power transformer or power supply



OPERATION

The output signal is available on one of the CO₂ terminals and is connected to the BAS analog input which reads the signal and calculates the CO₂ ppm value using correct scaling for the range and signal type. The CO₂ value is used to control output ventilation devices or initiate alarms.

If an optional temperature sensor is installed it will be wired to an analog input of the BAS that is set for the specific resistance type. This could be a 10K thermistor, a 1000Ω RTD or other sensor values. The BAS reads the resistance signal and converts it to a temperature value.

The device includes a red LED on the PCB to indicate correct operation. In warm-up mode (the first 1 minute after power is applied), the LED blinks at 2 times per second. After the warm-up period the LED will blink once every 4 seconds to indicate normal operation. If the CO₂ level is above the maximum scale (over-range), then the LED will blink once per second.

When activated for the first time a period of minimum 7 days is needed so that the algorithm can find its initial parameter set for Self Calibration. The sensor has to be exposed to fresh air for at least 1 hour every day. Also during that period, the sensor may not be disconnected from the power supply, otherwise the procedure to find calibration parameters is aborted and has to be restarted from the beginning

CALIBRATION

Every sensor is factory calibrated and will achieve stable long term operation due to using dual IR detectors and proprietary signal processing technology. The duct CO₂ sensor is designed for simple integration into any BAS system and for long term trouble free operation. As such, field calibration is not available or recommended on the product.

OUTPUT SIGNAL

The CO₂ output is scaled such that 4-20 mA or 0-5 Vdc or 0-10 Vdc equals 0 to 2000 ppm.

For 4-20 mA output type, connect the mA output terminal to the controller analog input. The COMMON terminal is the signal reference. Typically, this type of input would have a 250Ω input impedance.

If using voltage output type, connect the VOLT output terminal to the controller analog input. The COMMON terminal is the signal reference. Typically, this type of input would have a high impedance, >10 KΩ. The VOLT output signal can be scaled as 0-5 or 0-10 Vdc by changing the jumper position on the PCB.

SPECIFICATIONS

SENSOR

CO2 Sensor Dual channel non-dispersive infrared (NDIR)
Range..... 0-2000 ppm
Accuracy ± (30 ppm + 3% of reading)
Response Time 20 seconds (T63)
Sensor Life Span..... >15 years
Sensor Coverage Area..... 100 m² (1000 ft²) typical

OUTPUT

Output Signals4-20 mA, 0-5 Vdc, 0-10 Vdc (field selectable)
Drive Capability**Current:** 600 Ω max @ 24 Vdc
Voltage: 10K Ω min

POWER SUPPLY

Power Supply.....24 Vac/dc ± 15% (non-isolated half-wave rectified)
Consumption.....80 mA max @ 24 Vdc, 160 mA max @ 24 Vac
Protection.....Reverse voltage and transient protected

OPTIONS

Optional Temperature Sensor....Various RTDs or thermistors as a 2-wire resistance output

GENERAL

Probe152 mm L x 21.6 mm Diameter (6" x 0.85")
Enclosure Material.....ABS, UL94-V0, IP30 (NEMA 1)
Enclosure Dimensions84 mm W x 117 mm H x 29 mm D (3.3" x 4.6" x 1.1")
Warm-up Time.....1 minute
Temperature Dependency ±2.5 ppm/°C
Operating Conditions.....0 to 50°C (32 to 122°F), 0-90 %RH non-condensing
Storage Conditions-40 to 70°C (-40to 158°F), 0-85 %RH non-condensing
Wiring Connections.....Screw terminal block (14-22 AWG)
Approvals.....CE, RoHS
Country of Origin.....Canada

DIMENSIONS

