

INTRODUCTION

The CO₂ detector uses Infrared Technology to monitor CO₂ levels within a range of 0 – 2000 ppm or 0-20,000 ppm. Options include a control relay, RH and temperature sensors.

The device includes native RTU protocol with 12 Registers and an RS-485 network connection to offer a single-point solution for control of indoor air quality and comfort. Features include a back-lit LCD and user menu for easy installation.

BEFORE INSTALLATION

Read these instructions carefully before installing and commissioning the transmitter. Failure to follow these instructions may result in product

damage. Do not use in an explosive or hazardous environment, with combustible or flammable gases, as a safety or emergency stop device or in any other application where failure of the product could result in personal injury. **Take electrostatic discharge precautions during installation and do not exceed the device ratings.**

MOUNTING

The duct type sensor installs on the outside of a return air duct with the sampling tube inserted into the duct.

Mount the sensor in an easily accessible location in a straight section of duct at least five feet from corners and other items that may cause disturbances in the air flow. Avoid areas where the detector is exposed to vibrations or rapid temperature changes.

The duct CO₂ detector principal of operation is based on the Venturi effect of the probe that extends into the HVAC duct. Air flowing through the duct is forced into the vent holes on one side of the probe, into the enclosure, over the CO₂ sensor and then is drawn back out of the enclosure via the probe vent holes on the opposite side.

NOTE to ensure proper humidity and temperature readings, the RH/T inlet on the probe must be installed directly into the airflow. See Figure 1.

Drill or punch a 7/8" or 1" hole in the duct at the preferred location and insert the probe into the hole to mark the enclosure mounting holes. Remove the unit and drill the two mounting holes. Clean all drilled holes of debris before mounting the device.

Mount the enclosure to the duct with two sheet metal screws such that the duct air flow is parallel with the vent holes in the probe (i.e.: air flows directly into the probe holes). To prevent air leaks, ensure the gasket is compressed around the probe between the device enclosure and the air duct.

The enclosure has a hinged cover with a latch. Open the cover by pulling slightly on the latch on the right side of the enclosure, at the same time pulling on the cover, as illustrated in Figure 2.

A 1/2" NPT threaded connection hole is provided in the bottom of the enclosure. Screw the EMT connector or cable gland connector in until tight. See Figure 3. It is recommended that weatherproof conduit or cable gland fittings be used. The F style enclosure includes a 1/2" NPT to M16 thread adapter and cable gland fitting.

Make wiring connections as per the "Wiring" illustrations on Page 2.

Swing door closed until securely latched. For added security, 2 screws are provided that may be installed in the integrated screw tabs. See Figure 4.

Figure 1

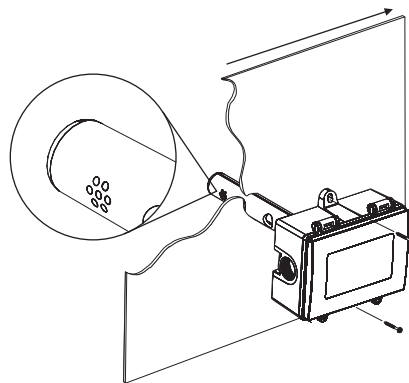

Figure 2

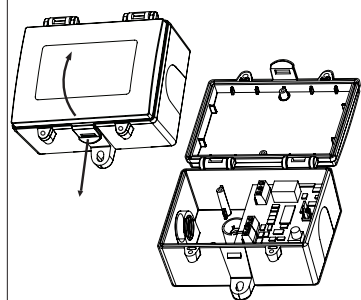

Figure 3

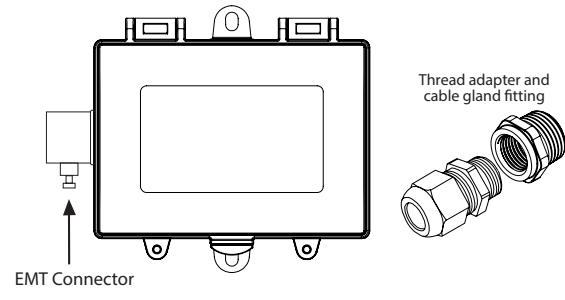
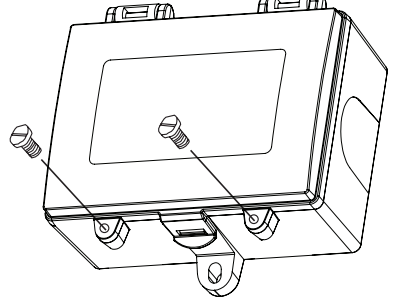

Figure 4



WIRING

Deactivate the 24 Vac/dc power supply until all connections are made to the device to prevent electrical shock or equipment damage. Follow proper electrostatic discharge (ESD) handling procedures when installing the device or equipment damage may occur.

Use 22 AWG shielded wiring for all connections and do not locate the device wires in the same conduit with wiring used to supply inductive loads such as motors. Make all connections in accordance with national and local codes.

Connect the 24 Vac/dc power supply to the terminals labeled POWER and COMMON. Use caution if 24 Vac power is used and one side of the transformer is earth-grounded. In general, the transformer should NOT be connected to earth ground when using devices with RS-485 network connections. The device is reverse voltage protected and will not operate if connected backwards.

Connect the RS-485 network with twisted shielded pair to the terminals marked A(-), B(+) and SHIELD. The positive wire connects to B(+) and the negative wire connects to A(-) and the cable shield must be connected to the SHIELD terminal on each device.

If the device is installed at either end of an RS-485 network, an end-of-line (EOL) termination resistor (121 ohm) should be installed in parallel to the A(-) and B(+) terminals. This device includes a network termination jumper and will connect the 121 ohm resistor correctly on the PCB.

Simply move the jumper to the EOL position and no external resistor is required. The ground wire of the shielded pair should be connected to earth ground at the end of the network and the master is not grounded.

Do not run bus wiring in the same conduit as line voltage wiring or other wiring that switches power to highly inductive loads such as contactors, coils or motors.

A network segment is a single shielded wire loop run between several devices (nodes) in a daisy chain configuration. The total segment length should be less than 4000 feet (1220 meters) and the maximum number of nodes on one segment is 255. Nodes are any device connected to the loop and include controllers, repeaters and sensors such as the CDD but do not include the EOL terminators.

To install more than 255 devices, or to increase the network length, repeaters will be required for proper communication. The maximum daisy chain length (segment) depends on transmission speed (baud rate), wire size and number of nodes. If communication is slow or unreliable, it may be necessary to wire two daisy chains to the controller with a repeater for each segment.

An optional signal is the relay output available on the N.O. RELAY terminals. The relay output is completely isolated and has a Normally Open (NO) signal. This signal can be used to directly control an alarm or ventilation fan.

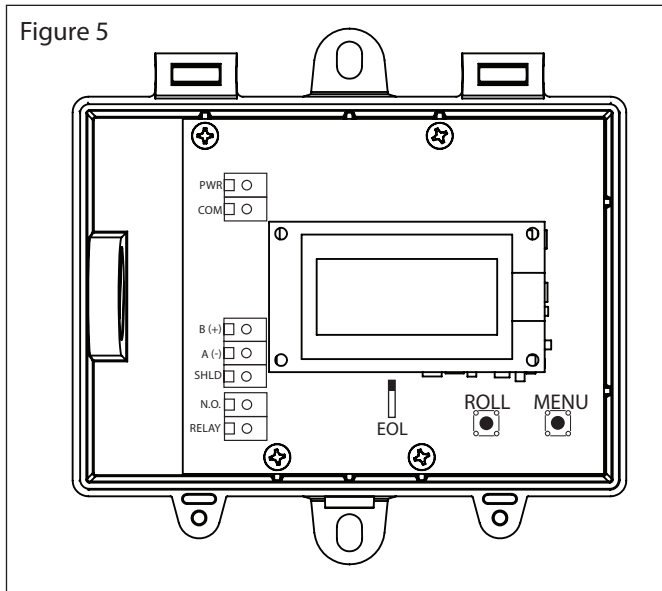

Figure 5

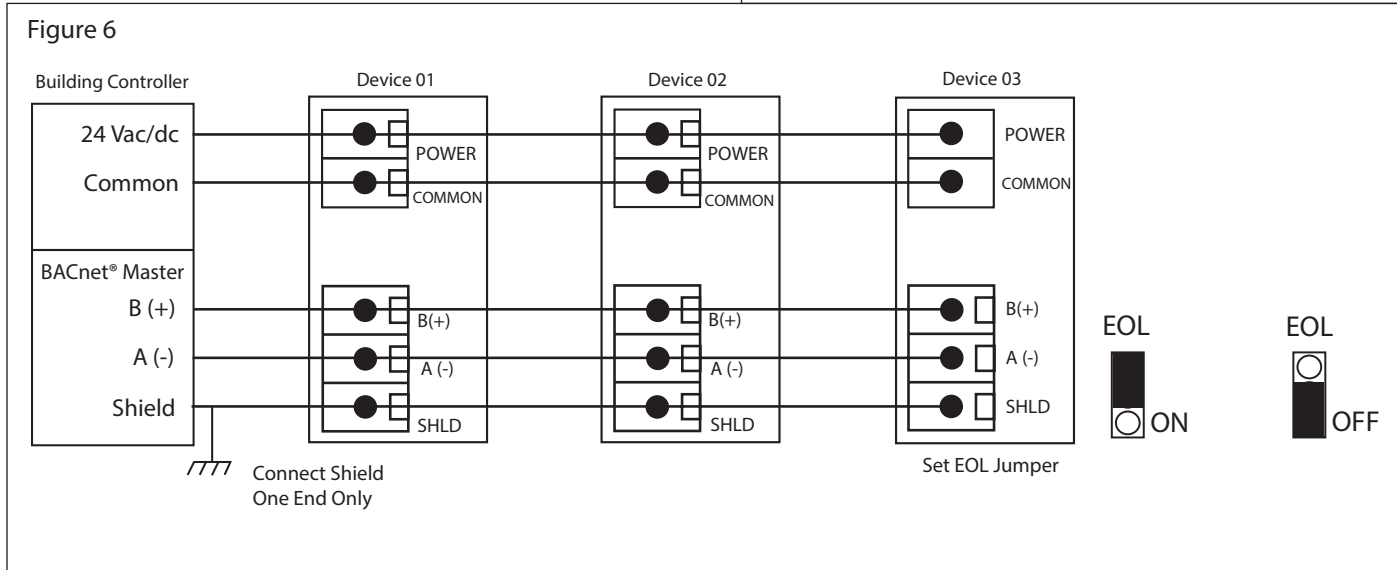

Figure 6

SET-UP

The device parameters must be set before connection to the network and will ensure each device will have a unique slave address for startup. Once set, all parameters are saved in non-volatile memory. The local menu and LCD are used to set the device address (1-255) and the baud rate. The factory defaults are address 3 and 9600 baud. The menu and setup procedure is described in the Start-up section.

START-UP

On start-up, the LCD will indicate the software version number, the slave address and the baud rate.

OPERATION

In normal operation the device reads the CO₂, RH and temperature sensors and updates the object values accordingly. The LCD displays the sensor values as determined by the display mode object.

USER MENU

The User Menu has several items as shown below. To enter the menu, press and release the <MENU> key while in normal operation. This will enter the User Menu step 1, pressing the <MENU> key a second time advances to step 2. The <ROLL> key is used to make changes to program variables by scrolling through the available options.

NOTE: If no keys are pressed for 5 minutes, the menu will automatically exit.

<MENU> Press and release to enter the SETUP menu

1. ADDRESS

*ModBus
Addr 1*

Use <ROLL> to select a unique slave address from 1-255. The default Modbus slave address is 1. Hold <ROLL> for 1 second to increment quickly.

<MENU> Press to advance to next menu item

2. BAUD RATE

*BaudRate
9600*

Use <ROLL> to select a baud rate of 9600, 19200, 38400, 57600, 76800 or 115200. The default Modbus baud rate is 9600.

<MENU> Press to advance to next menu item

3. PARITY

*ModBus
Parity N*

Use the <UP> or <DOWN> keys to select a parity value of N (none), O (odd) or E (even). The factory default Modbus parity bit is N (none).

<MENU> Press to advance to next menu item

4. STOP BITS

*ModBus
Stop 1*

Use the <UP> or <DOWN> keys to toggle the stop bits between 1 and 2 (for some configurations the value is fixed). The default stop bits is 1.

<MENU> Press to advance to next menu item

5. RTU MODE

*ModBus
CRC A001*

Use the <UP> or <DOWN> keys to select a CRC value of A001 (CRC-16 reverse), 1021 (CITT), 8005 (CRC-16) or 8408 (CITT reverse). The default RTU mode CRC polynomial is 0XA001.

<MENU> Press to advance to next menu item

6. SLAVE RESPONSE DELAY

*ModBus
Del MI*

Use the <UP> or <DOWN> keys to change the value from MI (minimum) to 50, 100, 150, 200, 250, 300, or 350ms. The factory default slave response delay is MI. (*minimum delay means just more than 3.5 character time delays, 4ms for 9600 baud rate, for example.*)

<MENU> Press to advance to next menu item

7. SLAVE RESPONSE DELAY

ModBus
Del MI

Use the <UP> or <DOWN> keys to change the value from MI (minimum) to 50, 100, 150, 200, 250, 300, or 350ms. The factory default slave response delay is MI. (*minimum delay means just more than 3.5 character time delays, 4ms for 9600 baud rate, for example*)

<MENU> Press to advance to next menu item

8. CALIBRATION

Calibrat
0 ppm

For dual channel NDIR CO₂ model only. This item is used for 0 ppm gas calibration and is explained in the *Calibration* section.

<MENU> Press to advance to next menu item

Calibrat
1000 ppm

This item is used for 1000 ppm gas calibration and is explained in the *Calibration* section.

<MENU> Press to advance to next menu item

Calibrat
20000 ppm

For dual channel NDIR CO₂ model only. This item is used for 20,000 ppm gas calibration and is explained in the *Calibration* section.

<MENU> Press to advance to next menu item

9. LCD BACKLIGHT

Backlite
Auto

Use <ROLL> to enable, disable or set to auto the LCD backlight. When enabled the LCD backlight is always on, when disabled it never lights and if it is set to Auto it lights for a time period (30) seconds whenever a key is pressed. The factory default is Auto

Menu
Exit

Press <MENU> or <ROLL> to exit the menu and return to normal operation.

CALIBRATION

The RH and temperature measurements typically do not need any calibration for the life of the product. Both values may have user offsets assigned in the Setup Menu.

CO₂ calibration with gas requires a field calibration kit with pressure regulator, necessary tubing and appropriate bottles of CO₂ gas. Note that the procedure depends on the device model.

SINGLE CHANNEL CALIBRATION

Calibration with gas requires a field calibration kit with pressure regulator, necessary tubing and appropriate bottles of CO₂ gas. Note that the procedure depends on the device model. The single channel model requires only a single point 1000 ppm calibration to meet specified accuracy due to the Automatic Calibration mode and other technology incorporated into the model.

1000 PPM CALIBRATION

Turn the regulator knob off and connect the 1000 ppm CO₂ gas bottle and hand tighten. Remove the cover of the unit to be calibrated to expose the gas sensor chamber. The tubing from the gas bottle can be connected to either port on the chamber after the plastic cap is removed. Gently remove one cap and connect the tubing, note that strong shock or vibration can affect calibration.. The CO₂ reading on the LCD will begin to approach 1000 ppm. Wait 1 to 2 minutes until the CO₂ reading stabilizes.

Enter the Setup menu and use the <MENU> key to advance to Calibrat 1000 PPM. Press and hold the <SAVE> key for 2 seconds and the display will change to Waiting Calibrat then to Waiting 5 minute to indicate that the device is calibrating. Again, this process takes about 5 minutes. When calibration is complete the unit will display the ppm value and Cal Done. Press the <SAVE> key to return to normal operation and shut the gas off.

Disconnect the tubing and replace the cap on the sensor chamber as calibration is complete.

DUAL CHANNEL CALIBRATION

Calibration with gas requires a field calibration kit with pressure regulator, necessary tubing and appropriate bottles of CO₂ gas. The dual-channel sensor with extended range requires a 3-point calibration with 0, 1000 and 20,000 ppm gas (in order).

0 PPM CALIBRATION

Turn the regulator knob off and attach it to the Nitrogen gas bottle and hand tighten. Remove the cover of the unit to be calibrated to expose the gas sensor chamber. The tubing from the gas bottle can be connected to either port on the chamber after the plastic cap is removed. Gently remove one cap and connect the tubing, note that strong shock or vibration can affect calibration.

Ensure the device has been operating normally for at least five minutes before applying gas. Turn the valve knob on the regulator to start the gas flow. The regulator will restrict the flow rate to the specified 100 ml/min. After a brief period the gas will flow into the chamber. Wait 1 to 2 minutes until the CO₂ stabilizes.

Enter the Setup menu and use the <MENU> key to advance to Calibrat 0 PPM. Press and hold the <SAVE> key for 2 seconds and the display will change to Waiting Calibrat then to Waiting 5 minute to indicate that the process of setting the internal calibration is taking place.

This takes about 5 minutes while the LCD counts down. Do not disturb the unit or the gas flow. When complete the unit will display the ppm value and Cal Done. Press <SAVE> to resume normal operation and shut the gas off.

1000 PPM CALIBRATION

Connect the 1000 ppm CO₂ gas bottle and apply the gas as before. The CO₂ reading on the LCD will begin to approach 1000 ppm. Wait 1 to 2 minutes until the CO₂ reading stabilizes.

Enter the Setup menu and use the <MENU> key to advance to Calibrat 1000 PPM. Press and hold the <SAVE> key for 2 seconds and the display will change to Waiting Calibrat then to Waiting 5 minute to indicate that the device is calibrating. Again, this process takes about 5 minutes. When calibration is complete the unit will display the ppm value and Cal Done. Press the <SAVE> key to return to normal operation and shut the gas off.

20,000 PPM CALIBRATION

Connect the 20,000 ppm CO₂ and apply the gas as before. The LCD will begin to approach 20,000 ppm. Wait 1 to 2 minutes until the CO₂ reading stabilizes.

Enter the Setup menu and use the <MENU> key to advance to Calibrat 20,000 PPM. Press and hold the <SAVE> key for 2 seconds and the display will change to Waiting Calibrat then to Waiting 5 minute.

Again, wait 5 minute and when calibration is complete the unit will display the ppm value and Cal Done. Press <SAVE> to resume normal operation and shut the gas off.

Disconnect the tubing and replace the cap on the sensor chamber as calibration is complete.

DIMENSIONS

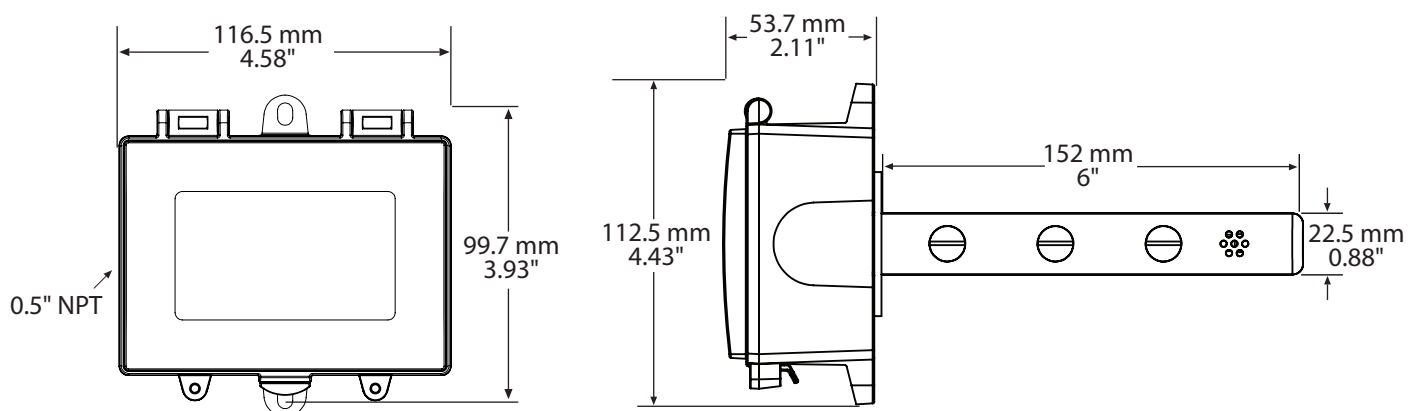

SPECIFICATIONS:

Power Supply	20 - 28 Vac/dc (non-isolated half-wave rectified)
Consumption	73 mA max @ 24 Vdc, 124 mA max @ 24 Vac with all options
Protection Circuitry.....	Reverse voltage protected, overvoltage protected
Operating Conditions	0 to 50°C (32 to 122°F), 0-95 %RH non-condensing
Wiring Connections.....	Screw terminal blocks, 14 to 22 AWG
Sensor Coverage Area.....	100 m ² (1000 ft ²) typical
Enclosure	Duct mount, Grey polycarbonate with gasket, UL94-V0, IP65 (NEMA 4X) F style includes thread adapter (1/2" NPT to M16) and cable gland fitting 116.5 W x 112.5 H x 53.7 D mm (4.585" x 4.43" x 2.115")
Probe.....	152 mm L x 22.5 mm D (6" x 0.89")

INTERFACE

Hardware	2-wire RS-485
Software	RTU protocol
Baud Rate.....	Locally set to 9600, 19200, 38400, 57600, 76800, or 115200
Slave Address	Locally set to 1-255 (factory default is 1)

LCD DISPLAY

Resolution	1 ppm CO ₂ , 1 %RH, 1°C (1°F)
Size	35 x 15 mm (1.4" x 0.6") alpha-numeric 2 line x 8 characters
Backlight	Enable or disable via keypad

CO₂ SIGNAL

Measurement Type	Non-Dispersive Infrared (NDIR), diffusion sampling
Measurement Range.....	0-2000 ppm (Sensor 1) or 0-20,000 ppm (Sensor 2), programmable span
Standard Accuracy	+30 ppm +3% or reading (Sensor 1 0-2000 ppm range with Auto Cal), +75 ppm or 10% of reading (whichever is greater) (Sensor 2 0-20,000 ppm range with dual channel sensor)
Temperature Dependence.....	0.2 %FS per °C
Stability	2 %FS over life of sensor (15 years typical) Sensor 1 (0-2000 ppm), <5 %FS over life of sensor (15 year typical) Sensor 2 (0-20,000 ppm)
Pressure Dependence.....	0.13% of reading per mm Hg
Altitude Correction	Programmable from 0-5000 ft via Modbus
Response Time	<2 minutes for 90% step change typical
Warm-up Time	<2 minutes

TEMPERATURE SIGNAL

Sensing Element.....	10K thermistor, +0.2°C (+0.4°F)
Range	0 to 50°C (32 to 122°F)
Resolution	0.1°C

RH SIGNAL

Sensor	Thermoset polymer based capacitive
Accuracy.....	±2 %RH
Range	0-100 %RH, non-condensing
Resolution	0.1 %RH
Hysteresis.....	+3 %RH
Response Time.....	15 seconds typical
Stability.....	+1.2 %RH typical @ 50 %RH in 5 years

OPTIONAL RELAY OUTPUT

Contact Ratings.....	Form A contact (N.O.), 5 Amps @ 250 Vac, 5 Amps @ 30 Vdc for resistive loads 2 Amps @ 250 Vac, 2 Amps @ 30 Vdc for inductive loads
Relay Trip Point.....	Programmable via Modbus
Relay Hysteresis.....	Programmable via Modbus

Country of Origin.....Canada

NETWORK SETUP GUIDE

The network setup guide describes the implementation of the BACnet® or Modbus protocol. It is intended to assist control system programmers who may need to add support to their systems to communicate with this device.

Modbus setup guide download is available online.



MODBUS PROTOCOL

<https://downloads.greystoneenergy.com/Website%20Documents/CHT/SG-CHTModXXX-01.pdf>