

INTRODUCTION

The CS-625 current switch is a solid-state switch that monitors line current for electrical loads such as pumps, conveyors, machine tools or fans and closes the output contacts when the adjustable trip point is exceeded. It is typically used to monitor motor operation and can be used to determine on/off status, proof of operation, motor failure or belt loss.

The sensor requires no external power as it is totally powered by induction from the primary AC line being monitored. The trip setpoint is adjustable in three jumper-selectable ranges from a minimum value (1 Amp) up to 175 Amps by rotating the adjustment pot counter-clockwise.

The output contacts can switch loads up to 1 Amp 240 Vac.

WARNING

- **Electric Shock Hazard, Use Caution**
- **Disconnect and lock out power before installation**
- Follow national and local electrical codes
- Read and understand these instructions before installing
- Installation only by qualified electrical personnel
- Do not rely on this device to indicate line power
- Only install this device on insulated conductors
- Only install on 600 Vac maximum conductors
- Do not use this device for life-safety applications
- Do not install in hazardous or classified locations
- Install this product in a suitable electrical enclosure
- Failure to follow these instructions may result in serious injury or death.

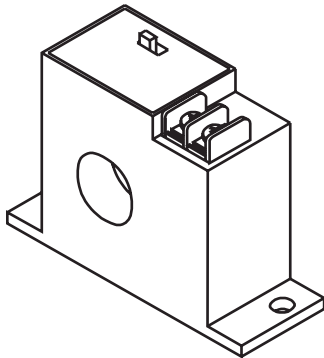

INSTALLATION

Read all warnings before beginning. Ensure the selected device has the correct ratings for application. Set the range jumper to the desired range. See Figure 1. Mount the sensor with two screws through the base.

The base has an integrated mounting tab to allow screw mount to a surface.

If predrilling is required, the actual device may be used to mark holes. The mounting holes in the base will accommodate up to a #10 size screw (Not supplied). See Figure 2. Place the monitored conductor through the sensor hole and reconnect. See Figure 3.

The CS-625 is not polarity sensitive. Use shielded wiring for all connections and do not locate the device wires in the same conduit with wiring used to supply inductive loads such as motors. Make all connections in accordance with national and local codes.

Reconnect the power.

Figure 1

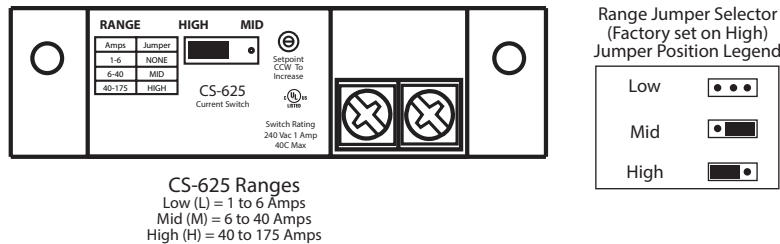

CS-625 Ranges
Low (L) = 1 to 6 Amps
Mid (M) = 6 to 40 Amps
High (H) = 40 to 175 Amps

Figure 3

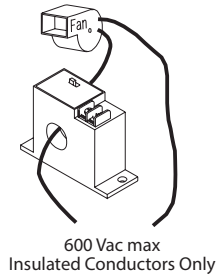

Figure 2

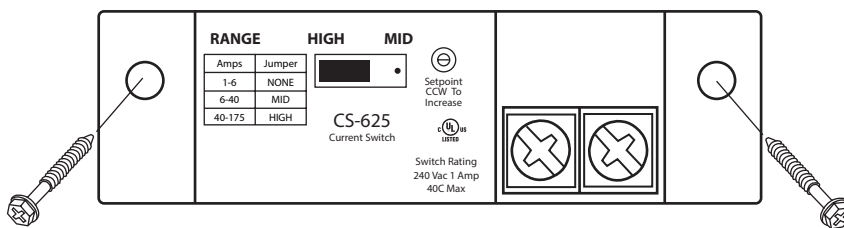

Figure 4

Wiring for using an external power supply

