

INTRODUCTION

The CSR-112 and CSR-124 command relay attaches to the side of any full-size CS or SC type sensor or switch and adds a form C relay function. It provides line voltage switching with control either from an automation system digital output or from a CS/SC current switch. A status LED indicates the relay state and the relay output features both a normally-open and a normally-closed contact.

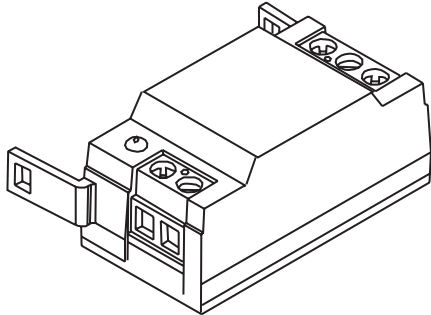

The CSR-CS/SC combination provides a convenient solution when status indication and motor control are needed at a single location. The CSR can accept a digital control signal from the controller to activate the relay contacts which can be used to provide power to the motor contactor to start the motor. The CS/SC switch will then provide a digital proof-of-flow signal to the controller to indicate motor status.

WARNING

- **Electric Shock Hazard, Use Caution**
- Disconnect and lock out power before installation
- Follow national and local electrical codes
- Read and understand these instructions before installing
- Installation only by qualified electrical personnel
- Do not rely on this device to indicate line power
- Only install this device on insulated conductors
- Only install on 600 Vac maximum conductors
- Do not use this device for life-safety applications
- Do not install in hazardous or classified locations
- Install this product in a suitable electrical enclosure
- **Failure to follow these instructions may result in serious injury or death.**



INSTALLATION

Read all warnings before beginning. Ensure the selected device has the correct ratings. Disconnect and lock out power.

Snap the CSR device onto the side of a CS product using the integrated mounting tabs as shown in Figure 1. Mount the CS switch with two screws through the base or snap onto a standard DIN mounting rail, as shown in Figure 2. Place the monitored conductor through the sensor hole. Wire the status output to the controller as shown in the wiring diagrams, see Figure X, they are not polarity sensitive. Wire the coil input to the controller or status switch as required. Wire the relay contacts to the load as required.

Reconnect the power.

OPERATION

The CSR command relay attaches to the side of any fullsize CS type sensor or switch and adds a form C relay function. It provides line voltage switching with control either from an automation system digital output or from a CS-610-200 or CS-GnG-200 current switch. A status LED indicates the relay state and the relay output features both a normally-open and a normally-closed contact.

The CSR/CS combination provides a convenient solution when status indication and motor control are needed at a single location. The CSR can accept a digital control signal from the controller to activate the relay contacts which can be used to provide power to the motor contactor to start the motor. The CS switch will then provide a digital proof-offlow signal to the controller to indicate motor status.

WIRING

The controller digital output (either 12 Vdc for CSR-112 or 24 Vdc for CSR-124) controls the CSR command relay coil input. When the coil signal is received, the CSR relay contacts close to

Figure 1

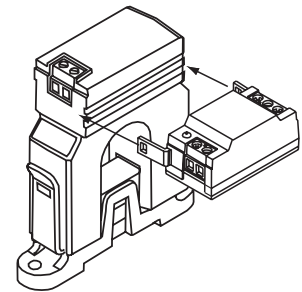

Figure 2

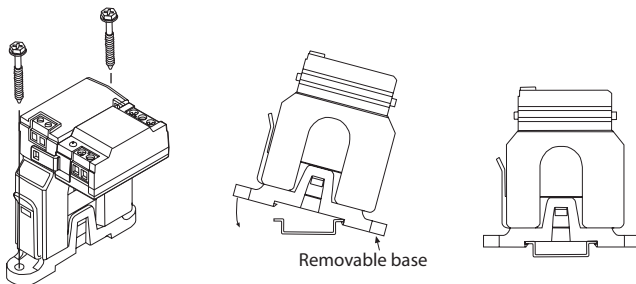
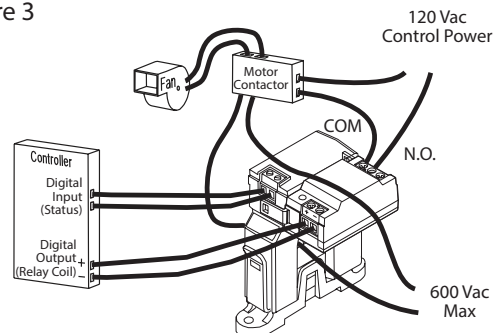

Figure 3



supply 120 Vac power to the motor contactor.

The motor contactor then switches the 600 Vac power to the fan and the fan starts. The CS-610 current switch monitors the current flow to the fan and when its trip level is exceeded, it supplies a digital input signal to the controller to indicate the fan status.

The CS-610 monitors the current to the heater. When the heater current exceeds the CS-610 trip point, the CS output contacts close to complete the low voltage circuit and 24 Vdc is applied to the CSR-124 coil input.

The energized coil input closes the CSR relay contacts and applies 120 Vac to the fan.

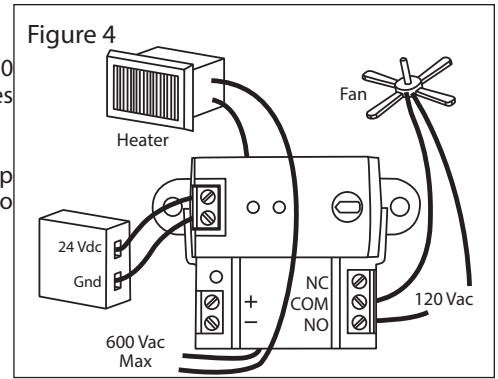

SPECIFICATIONS

Coil Voltage.....	CSR-112: 12 Vdc ±10%
	CSR-124: 24 Vac/dc ±10%
Coil Current.....	CSR-112: 25 mA maximum
	CS-124: 13 mA maximum
Relay Contacts	SPDT From C (NO + NC)
Contact Rating.....	5A @ 250 Vac/30 Vdc Resistive
	2A @ 250 Vac/30 Vdc Inductive
Contact Resistive	30 mΩ maximum
Ambient Operating Range.....	-15 to 60°C (5 to 140°F), 5 to 90 %RH, non-condensing
Terminal Block	14 to 22 AWG
Dimensions.....	50.8mm W x 35.6mm H x 21.2mm D
	(2" x 1.4" x 0.83")
Enclosure Material.....	ABS/PC, UL94 V-0
Manufacturing.....	ISO 9001 Certified
Agency Approvals.....	cULus Listed
Country of Origin.....	Canada

DIMENSIONS

