

INTRODUCTION

The differential pressure transmitter is designed with dual remote sensors that enable it to accept high pressure in ranges up to 5 PSI to 500 PSI. All models can handle overload pressure 2X the maximum fully scale range and burst pressure is 5X the maximum full scale range.

Features include field selectable pressure ranges and output signal types, output reversal and slow damping, port swapping and bidirectional measurements for the most flexible applications. The output signal is factory calibrated and temperature compensated for the highest start-up accuracy.

WARNING : Ensure that the maximum individual port pressure does not exceed the highest pressure range of the unit. For example, the highest individual port pressure on a 102 Range Code is 100 PSI. Exceeding this may damage the sensors and give erroneous readings. See Figure 12 for ratings.

BEFORE INSTALLATION

Read these instructions carefully before installing and commissioning the dewpoint transmitter. Failure to follow these instructions may result in product damage. Do not use in an explosive or hazardous environment, with combustible or flammable gases, as a safety or emergency stop device or in any other application where failure of the product could result in personal injury. **Take electrostatic discharge precautions during installation and do not exceed the device ratings.**

MOUNTING

The transmitter mounts on a vertical surface using the two integrated mounting holes. The remote sensor cable connection should be located on the bottom of the enclosure. The two mounting holes will facilitate a #10 size screw (not supplied). See Figure 1. Ensure there is enough space around the unit to make the electrical connections and that it is within an acceptable distance for the length of remote sensor cables. Avoid locations with severe vibrations or excessive moisture. The enclosure has a standard opening for a conduit connector or cable gland type fitting. In this position the High port is on the left and the Low port is on the right as shown on the PCB.

The enclosure has a hinged cover with a latch. Open the cover by pulling slightly on the latch on the bottom side of the enclosure and at the same time pulling on the cover, as illustrated in Figure 2.

A 1/2" NPT threaded connection hole is provided in the left side of the enclosure as shown in Figure 3. Screw the EMT connector or cable gland connector in until tight. See Figure 4. It is recommended that weatherproof conduit or cable gland fittings be used. The F style enclosure includes 1/2" NPT to M16 thread adapter and cable gland fitting.

Two security screws are provided which can be installed to help secure the cover once settings and wiring connections are complete. See Figure 4.

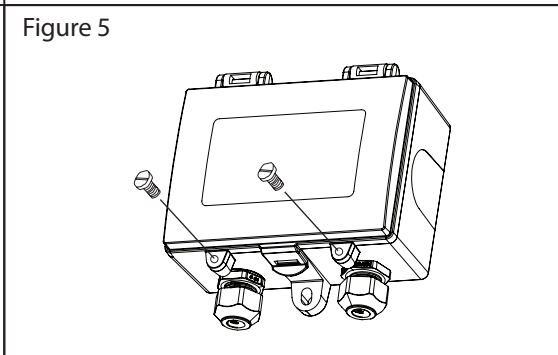
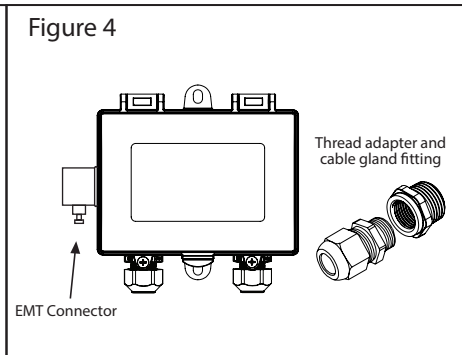
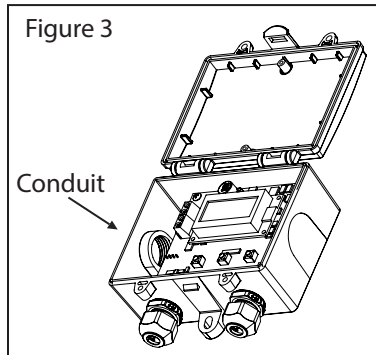
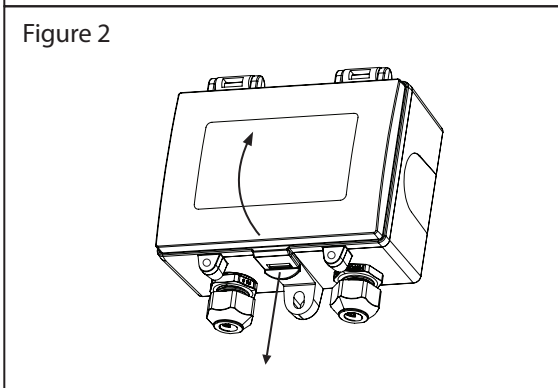
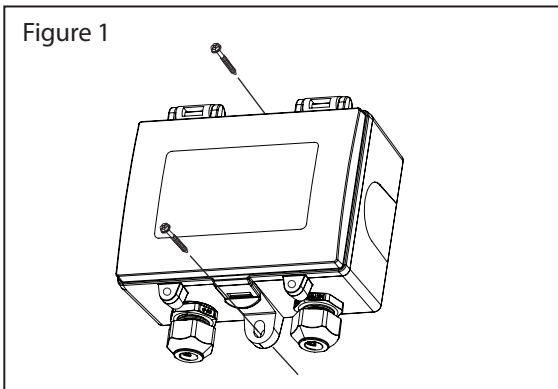

PLUMBING

The two stainless steel pressure sensors are labeled High and Low. The output signal will indicate a positive value when the pressure applied to the High sensor is greater than the pressure applied to the Low sensor, so ensure the sensors are connected correctly as shown in a typical application in Figure 6. Both sensors incorporate 1/4" NPT male threads for connection to the pipe being monitored. Do not allow material to fall into the pressure ports as contamination could damage the sensors. It is recommended to use Teflon tape to prevent leaks.

Remove the High pressure sensor from the remote cable by pressing on the release and pulling apart from the remote cable boot as shown in Figure 7. Wrap 1/4" NPT male sensor threads with Teflon tape. Screw into the sensor port on the pipe being monitored until finger tight. Use an appropriate size wrench to tighten the sensor until snug as shown in Figure 8. Reconnect the remote sensor cable you aligning the remote sensor cable boot and pushing firmly onto sensor. See Figure 9.

Repeat for the Low pressure sensor.

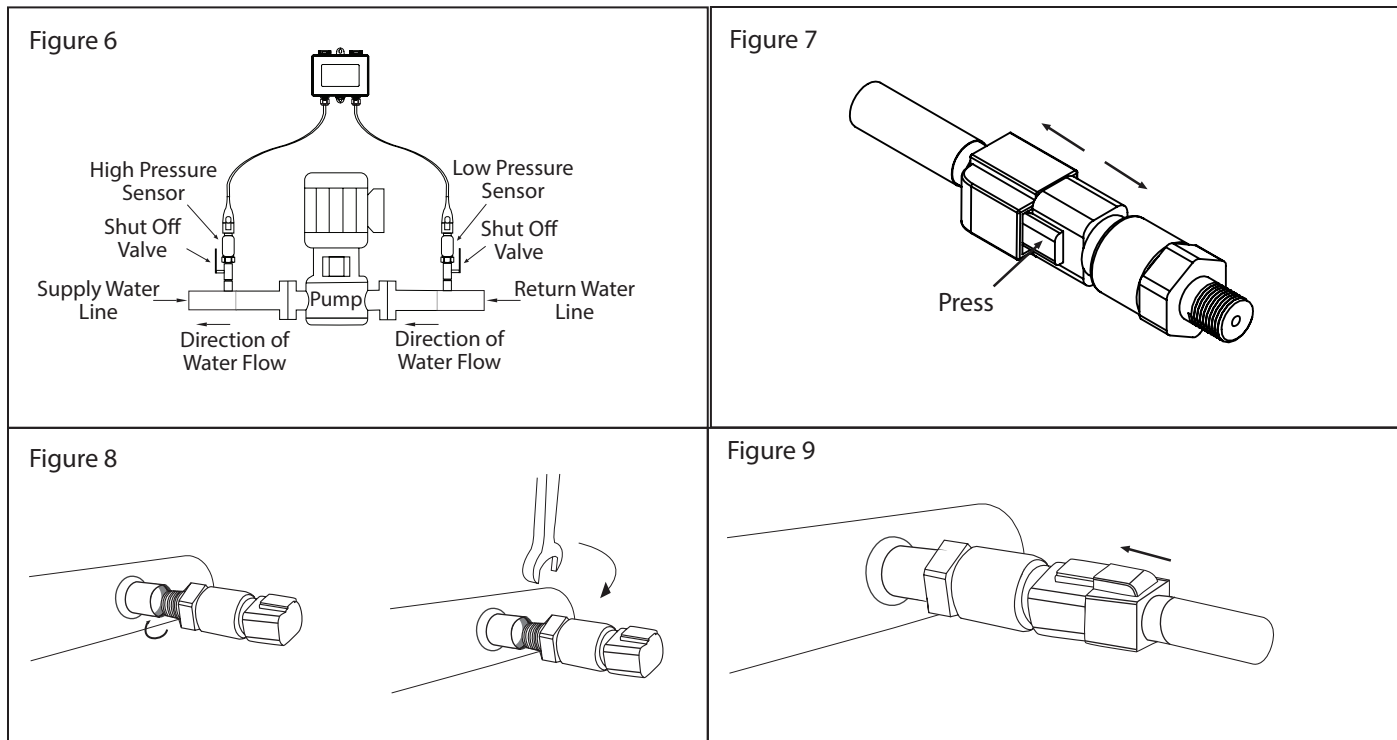

CONFIGURATION

Most configuration is done using User Menu setting with LCD and push buttons on PCB. See User Menu section for details.

Warning: The transmitter must not have power applied during set up or when making changes to the output signal.

Output Selection:

The transmitter features user-selectable output signals of 4-20 mA, 0-5 Vdc and 0-10 Vdc. It is factory configured to operate in the Current (4-20 mA output) mode, but can be changed to Voltage mode by sliding the output selection switch from the position marked mA to the position marked VOLT as shown in Figure 10.

In Voltage mode the output scale may be changed to either 0-5 or 0-10 Vdc by accessing under User Menu.

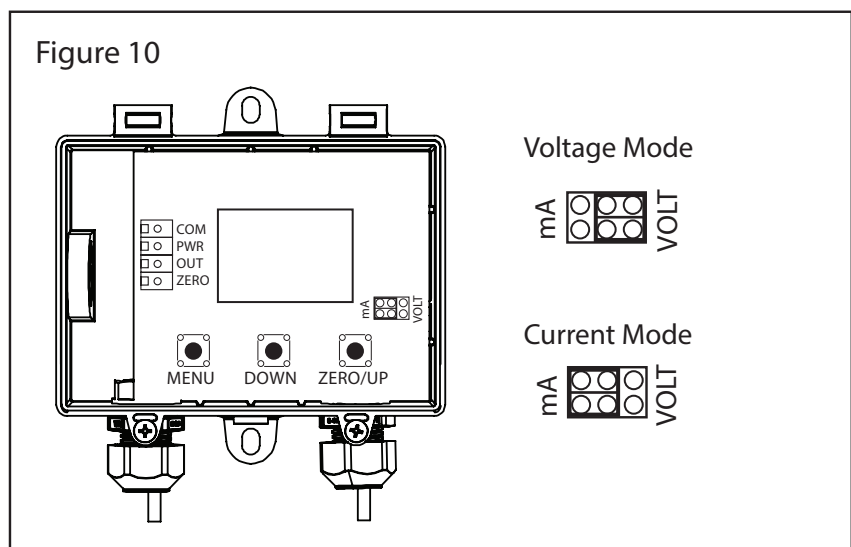

WIRING

- Deactivate the 24 Vac/dc power supply until all connections are made to the device to prevent electrical shock or equipment damage.
- Use 14-22 AWG shielded wiring for all connections and do not locate the device wires in the same conduit with wiring used to supply inductive loads such as motors. Make all connections in accordance with national and local codes.
- Pull at least six inches of wire into the enclosure, then complete the wiring connection according to the wiring diagram for the applicable power supply and output signal type.
- Connect the plus DC or the AC voltage hot side to the PWR terminal. For voltage output or AC power, the supply Common is connected to the COM terminal. **DO NOT connect power to the OUT terminals as the device will be damaged.** It has half-wave power supply so the supply Common is the same as the signal Common. See Figure 11.
- The analog output is available on the OUT terminal. Check the controller Analog Input to determine the proper connection before applying power.
- If using the Zero function, connect the Remote Zero Switch between the ZERO and COM terminals.

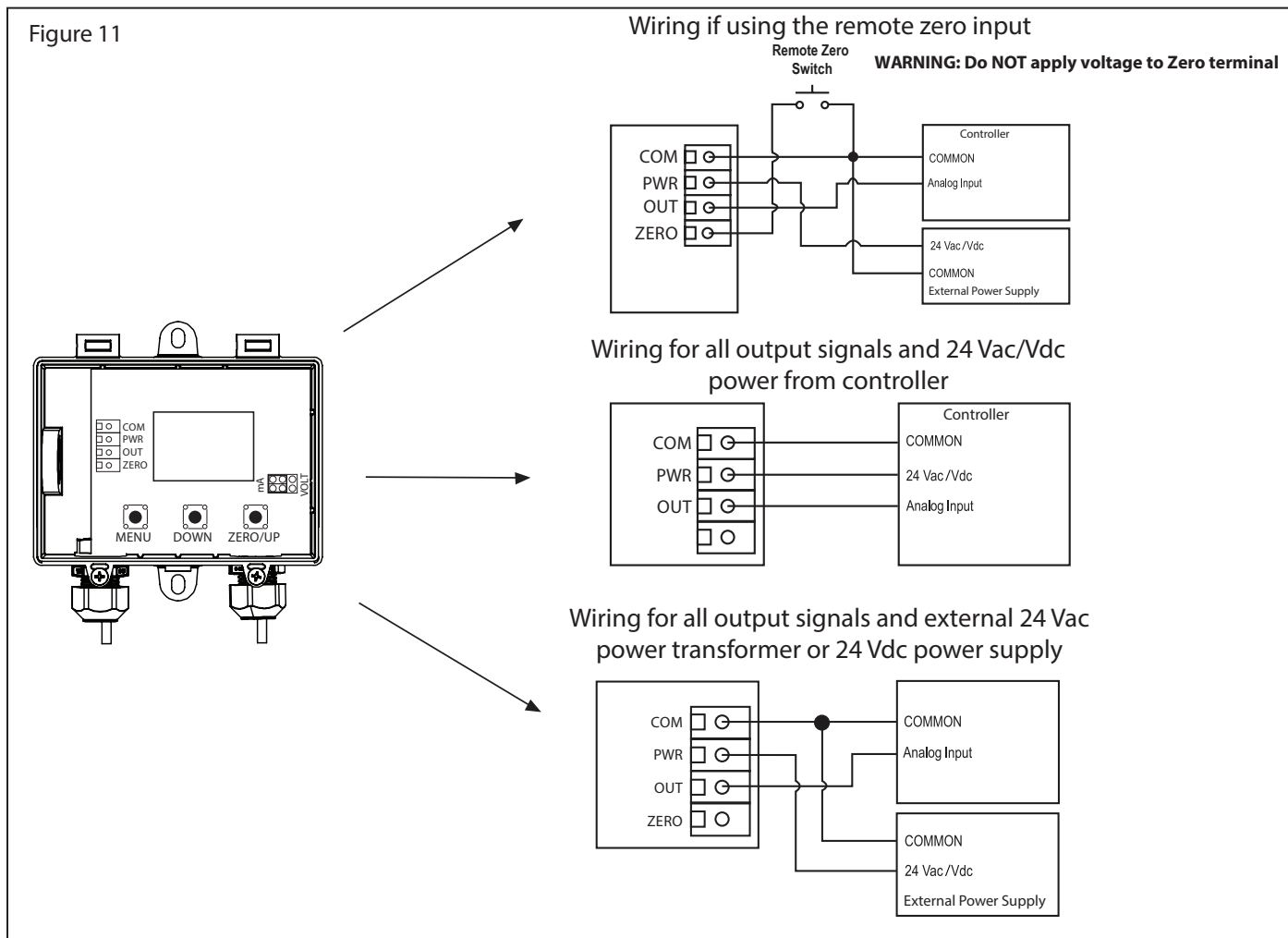

START-UP

Upon applying power to the device, it will enter the start-up mode. The LCD will display the current operating settings for 2 seconds each.

1. SOFTWARE VERSION NUMBER

Version
1.00

2. MODEL PRESSURE RANGE

P Range
50PSI

3. THE OUTPUT TYPE

Output
4-20mA

At the end of start-up mode the device will enter normal mode displaying pressure read from sensors.

0.0
PSI

USER MENU

The User Menu can be accessed by pressing the <MENU> key at any time after the start-up mode. Note that the <ZERO> key function changes to an <UP> key function when a menu is active.

The system suspends operation when in the menu and holds the last pressure value as the output value. If the User Menu is not active for 5 minutes (no key press), then the menu will exit and the device returns to normal operation.

The User Menu operation and parameters are explained below.

<MENU> Press and release the <MENU> key to enter the User Menu

1. OUTPUT

Output
0-5 Vdc

This item only appears if the PCB jumper is in the VOLT position. Use <UP> or <DOWN> to set the output signal type to 0-5 or 0-10 Vdc. The factory default is 0-5 Vdc.

<MENU> Press to save and advance to next menu item

2. PRESSURE RANGE

P. Range
500 PSI

The pressure range defaults to the largest range (1) of the device. Use <UP> or <DOWN> to step through the four available ranges specific to the model. Available options are shown below in Figure 12:

Model	PRESSURE RANGE			
	1	2	3	4
01	50 PSI	25 PSI	10 PSI	5 PSI
02	100 PSI	50 PSI	20 PSI	10 PSI
03	250 PSI	125 PSI	50 PSI	25 PSI
04	500 PSI	250 PSI	100 PSI	50 PSI
05	5.0 Bar	2.5 Bar	1.0 Bar	0.5 Bar
06	7.0 Bar	3.5 Bar	1.4 Bar	0.7 Bar
07	10 Bar	5 Bar	2 Bar	1 Bar
08	35 Bar	17.5 Bar	7 Bar	3.5 Bar
09	500 kPa	250 kPa	100 kPa	50 kPa
10	700 kPa	350 kPa	140 kPa	70 kPa
11	1000 kPa	500 kPa	200 kPa	100 kPa
12	3500 kPa	1750 kPa	700 kPa	350 kPa

<MENU> Press to save and advance to next menu item

3. PRESSURE SCALE

P Scale
0 - Max

The default pressure scale is unidirectional 0 to full-scale (ex: 0 - 500 PSI). Use <UP> or <DOWN> to toggle the setting to a bi-directional scale (ex: \pm 500 PSI). The setting changes from "0 - Max" to "+/- Max".

<MENU> Press to save and advance to next menu item

4. DAMPING

Damping
4 sec

The pressure averaging time for surge damping defaults to 4 seconds. This can be changed from 1 to 60 seconds using <UP> or <DOWN>.

<MENU> Press to save and advance to next menu item

5. OUTPUT

Output
Direct

The analog output defaults to Direct (4-20 mA, 0-5 Vdc or 0-10 Vdc). Use <UP> or <DOWN> to change it to Reverse (20-4 mA, 5-0 Vdc or 10-0 Vdc).

<MENU> Press to save and advance to next menu item

6. PRESSURE PORT

P. Port
Direct

The Pressure Port defaults to Direct (HIGH Port = High Pressure, LOW Port = Low Pressure). Use <UP> or <DOWN> to change it to Reverse (HIGH Port = Low Pressure, LOW Port = High Pressure) if it is necessary to swap the ports due to a plumbing error.

<MENU> Press to save and advance to next menu item

7. BACKLIGHT

Backlite
Auto

The backlight operation defaults to Auto operation. It can be set to Off or On Auto using <UP> or <DOWN>. Auto means the LCD backlight only lights when a menu is accessed, off means it never lights and on means it is always on.

<MENU> Press to exit and return to normal operation.

OPERATION

During normal mode the device reads the pressure sensors and calculates the pressure value depending on the selected range. The pressure value is displayed on the LCD and set as the output value for the analog output. The output value is updated once per second.

For normal operation such as 0-100 PSI, the pressure applied to the High port must be higher than the pressure applied to the Low port. If the pressure connection is reversed then the transmitter will always output 4 mA. If the Low port is left open to ambient pressure, then the High port is used to measure a positive pressure and 0 PSI = 4 mA and 100 PSI = 20 mA.

For bi-directional operation such as ± 100 PSI, the pressure applied to the High port should be higher than the pressure applied to the Low port for a positive output response. Negative pressure is indicated if the High pressure is less than the Low pressure. In this case -100 PSI = 4 mA and +100 PSI = 20 mA. Since the transmitter is linear 0 PSI = 12 mA.

The output value may be affected by device settings such as the pressure damping time. The pressure averaging setting controls how many readings are averaged to form the output value. For example, if the pressure averaging value is set to 30 seconds then 30 one-second readings are stored and averaged to form the output value. The next second will add a new reading and delete the first to form a new 30 second average for output. The output gets updated every second with a new average reading. The averaging value can be set from 1 to 60 seconds via the User Menu.

During normal mode, the device also monitors the <ZERO / UP>, <DOWN> and <MENU> keys and takes appropriate action. The keys are used to access the User Menu. The device also monitors the Volt/mA jumper to determine the appropriate output scaling. The voltage span may be set via the User Menu to either 0-5 Vdc or 0-10 Vdc.

A sensor auto-zero can be initiated by pressing and holding the internal <ZERO> switch for at least 3 seconds. If both pressure ports are close to zero pressure, then the device will calibrate with a new zero point. The auto-zero can also be initiated by holding the ZERO terminal low for 3 seconds.

Generally, it is not recommended that a span calibration be performed in the field unless a high-quality calibrator with low differential pressure ranges is available and the temperature of the sensor can be maintained.

SPECIFICATIONS

Power Supply	24 Vac/dc \pm 10% (non-isolated half-wave rectified)
Consumption	75 mA max @ 24 Vdc
Output Signal	4-20 mA sourcing, 0-5/0-10 Vdc (switch selectable)
Output Drive	Current: 500 ohms max Voltage: 10K ohms min
Protection Circuitry	Reverse voltage protected, transient protected
LCD	35 x 15 mm (1.4 x 0.6"), 2-line x 8-character
Accuracy	\pm 1% F.S. of selected range (range 4 is \pm 2% F.S.) @ 22°C (72°F) including hysteresis, non-linearity and repeatability
Stability	\pm 0.25% FS typical (1 year)
Pressure Ranges	4 per model (menu selectable)
Media Compatibility	17-4 PH stainless steel
Proof Pressure	2X highest range per model
Burst Pressure	20X highest range per model
Maximum Line Pressure	= highest model range
Pressure Cycles	> 100 million
Surge Damping	1-60 seconds averaging (menu selectable)
Zero Adjust	Push-button and remote input
Sensor Operating Range	-40 to 105°C (-40 to 221°F)
Operating Environment	0 to 50°C (32 to 122°F), 10 to 90 %RH non-condensing
Pressure Connection	1/4" NPT male
Sensor Housing	IP67
Remote Sensor Cable	S: FT-6 plenum rated A: Armored Flexible S/S
Wiring Connection	14-22 AWG screw terminal block
Enclosure	Polycarbonate, UL94-V0, IP65 (NEMA 4X) F style includes thread adapter (1/2" NPT to M16) and cable gland fitting
Dimensions	112.5 W x 116.5 H x 53.7 D mm (4.43" x 4.59" x 2.11")
Weight	650g (22.9 oz) - Including remote cables and sensors
Country of Origin	Canada

DIMENSIONS

