

### INTRODUCTION

The outside dewpoint transmitter is designed for use in environmental monitoring and control systems where high performance and stability are demanded. It's state-of-the-art design combines digital linearization and temperature compensation with a highly accurate and reliable thermoset polymer based capacitance humidity sensor and curve-matched NTC thermistor temperature sensor for reliability and accuracy in the most critical applications. A polycarbonate weatherproof enclosure is provided for ease of installation with an integrated sun and windshield.

### BEFORE INSTALLATION

Read these instructions carefully before installing and commissioning the transmitter. Failure to follow these instructions may result in product damage. Do not use in an explosive or hazardous environment, with combustible or flammable gases, as a safety or emergency stop device or in any other application where failure of the product could result in personal injury. Take electrostatic discharge precautions during installation and do not exceed the device ratings.

### MOUNTING

Select a suitable mounting spot on an exterior wall where the sensor is best protected from direct exposure to sunlight, wind, etc. preferably on a north facing wall. Do not mount the sensor near opening windows, supply/exhaust air louvres or other known air disturbances. Avoid areas where the sensor is exposed to vibrations or rapid temperature changes.

The enclosure provides a connection hole for 1/2" Conduit. Run a length of conduit through exterior wall and seal. Use 14-22 AWG shielded wiring for all connections and do not locate the device wires in the same conduit with wiring used to supply inductive loads such as motors. Make all connections in accordance with national and local codes.

The sensor installs directly on an exterior wall using the two integrated mounting holes are provided on the enclosure. Select the best mounting technique based on the exterior wall material. The 2 mounting holes will facilitate a #10 size screw (not supplied). The sensor fitting must be pointing down. See Figure 1.

The enclosure has a hinged cover with a latch. Open the cover by pulling slightly on the latch on the right side of the enclosure. At the same time pulling on the cover, as illustrated in Figure 2.

Feed conduit through the provided hole in the back of the enclosure and secure with a lock nut as shown in Figure 3. It is recommended that weatherproof conduit or cable gland fittings be used.

Make wiring connections as per the "Wiring" illustrations on Page 2.

Swing door closed until securely latched. For added security install the two supplied security screws as shown in Figure 4.

Figure 1

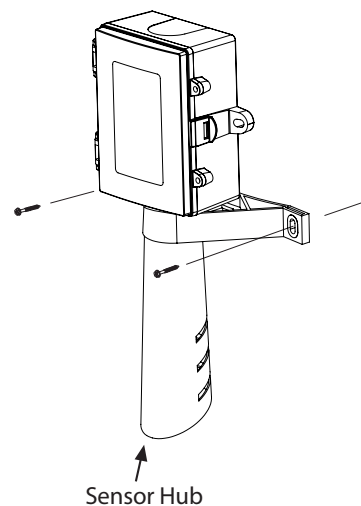

Figure 2

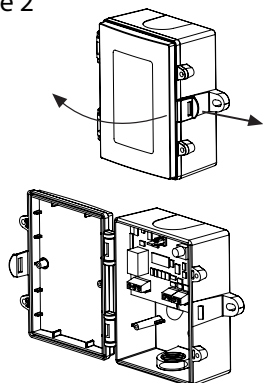

Figure 3

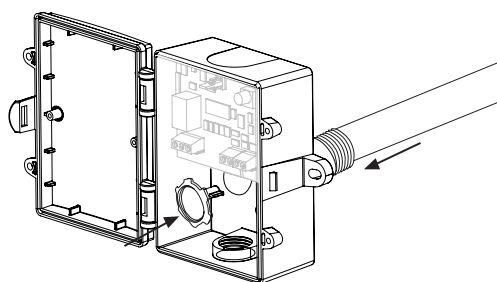
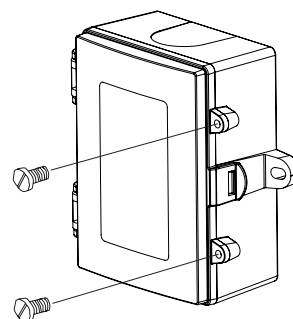

Figure 4



## WIRING

- Deactivate the 24 Vac/dc power supply until all connections are made to the device to prevent electrical shock or equipment damage.
- Follow proper electrostatic discharge (ESD) handling procedures when installing the device or equipment damage may occur.
- Use 22 AWG shielded wiring for all connections and do not locate the device wires in the same conduit with wiring used to supply inductive loads such as motors.
- Make all connections in accordance with national and local codes.

Connect the 24 Vac/dc power supply to the terminals labeled PWR (power) and COM (common) as shown in Figure 6. This device has a half-wave type power supply so use caution when wiring multiple devices so that the circuit ground point is the same on all devices and the controller. The device is reverse voltage protected and will not operate if connected backwards.

Figure 5

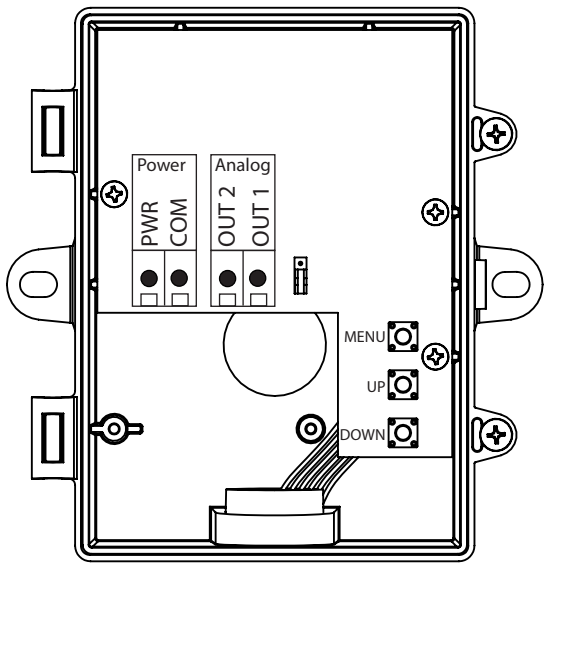
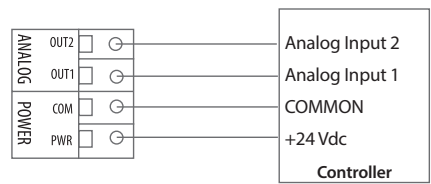
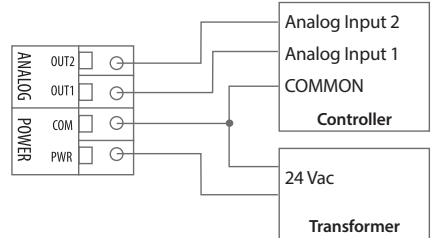

Figure 6

Wiring for all output signals with power from controller



Wiring for all output signals with external power supply or transformer



## OPERATION

### START-UP MODE

When the device is powered on, it will go through a brief start-up mode. The LCD will display a sequence of information depending on the model. At the end of the start-up sequence, normal operation will begin.

**STEP 1** LCD Test  
All segments lit for 2 seconds



**STEP 2** Model  
Displays the model type for 2 sec.  
(Volt or current depending on model ordered)



**STEP 3** Software Version for 2 sec



## NORMAL MODE

In normal operation the device:

- reads the temperature and RH sensors
- calculates values for dewpoint, wet bulb and enthalpy
- updates the LCD values
- updates the analog outputs
- monitors the menu key for activity

If the <MENU> key is pressed, normal operation is suspended while the menu functions are serviced. The program will automatically exit the menu after a period of inactivity.

## MENU

The device has several parameters that can be configured locally via the User menu using the keypad and LCD. All parameters default to typical values but the installer may want to change some values. Any changes made are saved in non-volatile memory and are restored in case of a power loss. Only the menu items relevant to the device model will be shown. The menu can be accessed at any time after the start-up mode and if there is 5 minutes of inactivity the menu will close and normal operation will continue.

### User Menu

To enter the menu, press and release the <MENU> key. This will enter the User menu step 1, pressing the <MENU> key a second time advances to step 2. Each press of the <MENU> key saves the current setting and advances the menu item. The <UP> and <DOWN> keys are used to make changes to program variables by scrolling through the available options. When a value is changed, use the <MENU> key to save it to memory and advance to the next menu item.

<MENU> Press and release to enter the User menu.

### 5V / 10V (default = 5V)

(This item is only shown for the voltage output model.)

Use <UP> or <DOWN> to toggle the selection.



<MENU>

### Output Signal 1

#### Temperature Range (default = -30-50 °C)

This item sets the dry bulb temperature range for OUT1.

Use <UP> or <DOWN> to toggle -30-50 °C, 0-50 °C, -22-122 °F or 32-122 °F.



<MENU>

### Output Signal 2 (default = Td)

This item selects the OUT2 parameter.

Use <UP> or <DOWN> to toggle Td, Tw or Enthalpy.

The display is either "Td", "Tw" or "kJ/kg + BTU/lb".



<MENU>

Only 1 of the next 3 items is shown, depending on what parameter is selected for Output Signal 2  
The shown scale (C/F) depends on the previous Temperature Range selection

### Dewpoint Temperature Range (default = -30-50 °C or -22-122 °F)

This item sets the dewpoint temperature range for OUT2.

Use <UP> or <DOWN> to toggle either -30-50, -20-40 or 0-50 for °C, or -22-122, -4-104 or 32-122 for °F. Td is lit + either °C or °F.

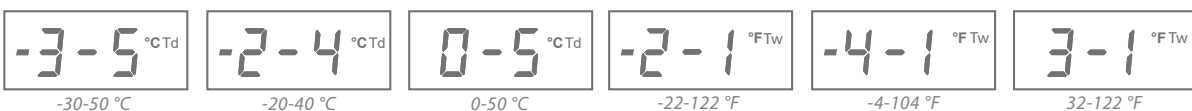

### Wet Bulb Temperature Range (default = -20-50 °C or -4-122 °F)

This item sets the wet bulb temperature range for OUT2.

Use <UP> or <DOWN> to toggle either -20-50 or 0-50 for °C, or -4-122 or 32-122 for °F.

The display is similar to Td, except Tw is lit + either °C or °F



### Enthalpy Range (default = 0-340 kJ/kg)

This item sets the enthalpy range for OUT2 and also the units.

Use <UP> or <DOWN> to toggle either 0-250 kJ/kg, 0-340 kJ/kg, 0-107 BTU/lb or 0-146 BTU/lb. Unit is lit + max value.



<MENU>

### LCD (default = Out1)

This item selects what parameter are displayed on the LCD.

Use <UP> or <DOWN> to toggle Out1, Out2 or both (toggle).

The display is either L1, L2 or L12.



<MENU>

### Temperature Offset (default = 0 °C or 0 °F)

This item is for field calibration and is used to add an offset to the temperature measurement.

Use <UP> or <DOWN> to change from -10-10 °F or -5-5 °C. Either °C or °F is lit.

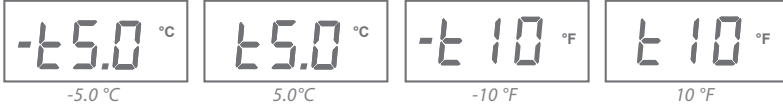

<MENU>

### RH Offset (default = 0 %RH)

This item is for field calibration and is used to add an offset to the RH measurement.

Use <UP> or <DOWN> to change from -10-10 %RH.



-10% RH

<MENU>

### Altitude (default = 0 ft)

This item is to set the local altitude to increase calculation accuracy.

Use <UP> or <DOWN> to change from A 0 to A60. Resolution is 100 ft steps.



6000 FT

<MENU>

Exits the menu and returns to normal operation.

### DIMENSIONS

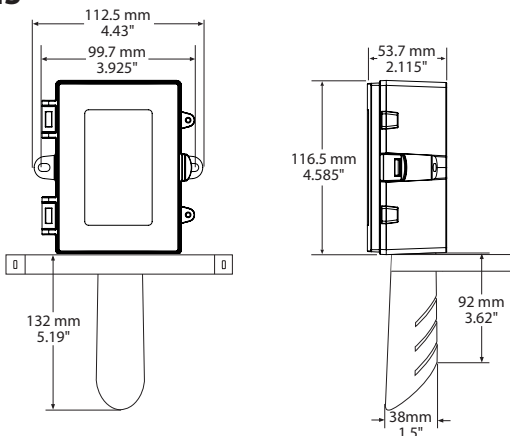

## SPECIFICATIONS:

### Sensor Type

RH Sensor.....Thermoset polymer based capacitive  
Temperature Sensor.....NTC Thermistor

### Measurement Range:

Relative Humidity .....0 - 100 %RH  
Dry Bulb Temperature .....-30 to 50 °C (-22 to 122 °F)

### Calculated Values:

Dewpoint Temperature .....-30 to 50 °C (-22 to 122 °F)  
Wet Bulb Temperature .....-30 to 50 °C (-22 to 122 °F)  
Enthalpy .....0 – 340 kJ/kg (0 – 146 BTU/lb)

### Accuracy:

Relative Humidity (RH) .....± 2% RH, 10 – 90 %RH @ 25 °C  
Dry Bulb Temp.(T).....± 0.2 °C (± 0.4 °F) / 0 to 50 °C (32 to 122 °F)  
Dewpoint Temp. (Td).....± 1.0 °C (± 1.8 °F) @ 40 %RH / 25 °C  
Wet Bulb Temp. (Tw).....± 1.0 °C (± 1.8 °F) @ 50 %RH / 25 °C  
Enthalpy (En) .....± 2 kJ/kg (± 1 BTU/lb) @ 50 %RH / 25 °C

### Output:

Output Signals (2X).....4 – 20 mA or 0-5/0-10 Vdc (factory set)  
Signal 1.....Dry Bulb Temperature (field selectable range)  
T Range 1 = -30 to 50 °C (-22 to 122 °F)  
T Range 2 = 0 to 50 °C (32 to 122 °F)  
Signal 2.....Dewpoint Temperature, Wet Bulb Temperature or Enthalpy (field selectable)  
Td Range 1 = -30 to 50 °C (-22 to 122 °F)  
Td Range 2 = -20 to 40 °C (-4 to 104 °F)  
Td Range 3 = 0 to 50 °C (32 to 122 °F)  
Tw Range 1 = -20 to 50 °C (-4 to 122 °F)  
Tw Range 2 = 0 to 50 °C (32 to 122 °F)  
En Range 1 = 0 – 340 kJ/kg (0 – 146 BTU/lb)  
En Range 2 = 0 – 250 kJ/kg (0 – 107 BTU/lb)  
Output Impedance .....500 Ω max for current (@ 24 Vdc), 10 KΩ min for voltage

### Specifications:

Power Supply.....20 – 27 Vdc, 16 – 27 Vac (non-isolated half-wave rectified)

### Consumption:

Current model .....50 mA max @ 24 Vdc, 1.5 VA max @ 24 Vac  
Voltage model.....30 mA max @ 24 Vdc, 1 VA max @ 24 Vac

### Operating Conditions:

Operating Conditions.....-30 to 50 °C (-22 to 122 °F), 0 – 95 %RH non-condensing  
Storage Conditions .....-40 to 70 °C (-40 to 158 °F), 0 – 95 %RH non-condensing  
Wiring Connections.....14 to 22 AWG terminal block

### Enclosure:

Dimensions .....112.5W x 116.5H x 53.7D mm (4.43W x 4.585H x 2.115D in)  
Material .....Grey polycarbonate with gasket, UL94-V0  
Ratings.....IP65 (NEMA 4X)

Probe.....25.4 mm (1.00") L x 25.4 mm (1.00") D, PVC hub with mesh filter

Approvals.....CE, RoHS

### LCD Display Values:

Temperature.....-30.0 to 50.0 °C (0.5 °C resolution) or -22 to 122 °F (1 °F resolution)  
Dewpoint.....-30.0 to 50.0 °C Td (0.5 °C resolution) or -22 to 122 °F Td (1 °F resolution)  
Wet Bulb.....-20.0 to 50.0 °C Tw (0.5 °C resolution) or -4 to 122 °F Tw (1 °F resolution)  
Enthalpy .....0 – 340 kJ/kg (1 kJ/kg resolution) or 0 – 146 BTU/lb (1 BTU/lb resolution)

Country of Origin .....Canada