

INTRODUCTION

The electronic to pneumatic transducer converts an electrical input signal to a pneumatic output signal to position pneumatic damper and valve actuators in HVAC systems. The transducer provides a linear 3-15 PSI output in response to a 4-20 mA, 0-10 Vdc or PWM input.

BEFORE INSTALLATION

Disconnect the power supply before installation and do not exceed device ratings. Make all connections in accordance with the wiring diagram and electrical codes. Particles in the air supply larger than 0.03 microns may adversely affect the reliability and life of the transducer. A K-335 in line air filter is recommended for installation between the main air supply and the main air port of the device. A refrigerated air dryer, particulate filter and coalescing filter should provide a quality air supply. Compressor oil must be non-paraffin mineral base of naphtha base. Synthetic base oils will destroy pneumatic controls and void the warranty. Do not locate the unit in areas subject to incidental contact, vibration, severe mechanical shock, excessive moisture, or corrosive fumes. **The ETP-9500, ETP-9510, and ETP-9520 transducers must be mounted within 5° of the upright position. See the "UP" arrow on the PCB or label.**

MOUNTING

Select the mounting location and mount the device **with the "UP" arrow pointing upwards** using the two screws through the base of the snap track. The PCB may be removed from the snap track for easier installation. See Figure 1. Ensure that the screw heads do not contact the PCB.

If the enclosure is present, use a Phillips screw driver to remove the (2) screws, as shown in Figure 3. Mount the enclosure to a vertical surface within 5° of perfectly vertical ensuring the device is upright, **using the "UP" arrow on the PCB** as a guide. The enclosure is to be secured using the two integrated screw tabs using #10 self tapping screws (not supplied). See Figure 4.

Make all necessary electrical connections as per the wiring illustrations on page 2.

Connect the pneumatic lines to the unit, ensuring that the main air supply is connected to the black tube and the branch line is connected to the clear tube. The main and branch lines are also labeled on the end of the valve with a "M" and a "B". See Figure 2.

The device may be tested by applying the input ZERO signal (either 4 mA, 2 Vdc, or 0 Vdc as applicable) and checking the output for a pressure of 3 PSIG (21 kPa). Then adjust the input for the SPAN signal (either 20 mA or 10 Vdc) and re-check the output for a pressure of 15 PSIG (103 kPa). The device is factory calibrated for these ranges and should not be readjusted in the field.

If the unit does not perform as indicated, then verify all applicable electrical signals (4 mA, 20 mA, 0 Vdc, 10 Vdc, and the power supply) using a multimeter. Also verify that the input air supply is 20-30 PSIG (138-207 kPa) and that the unit is properly mounted and that all wiring is per the wiring illustrations.

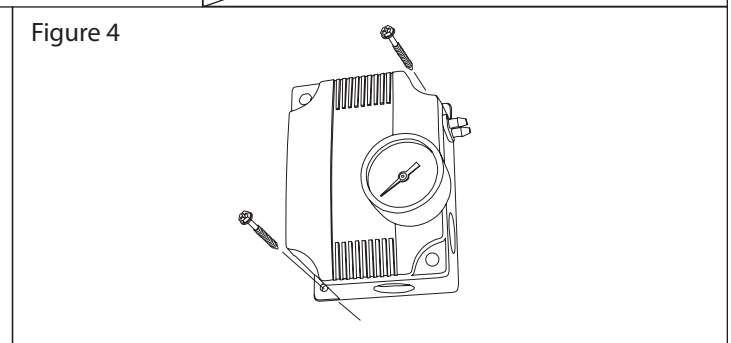
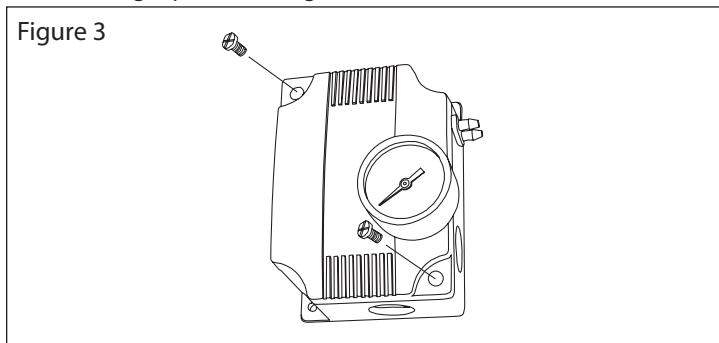
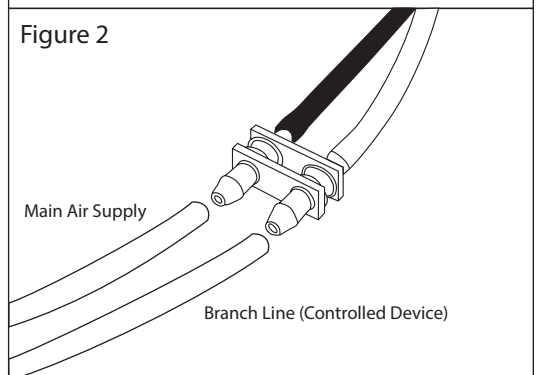
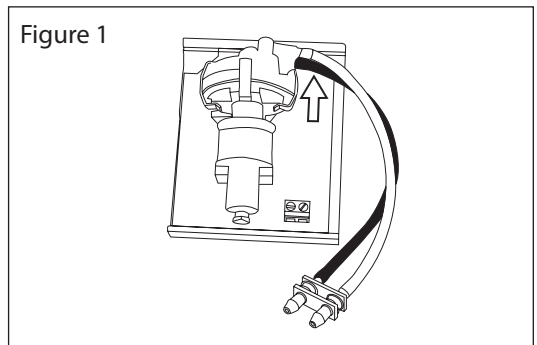

WIRING

The ETP-9520 is a loop powered 4-20 mA device and requires a 4-20 mA signal to be connected to the INPUT terminal and the system common connected to the COM terminal. The ETP-9500 requires a jumper selection for the input signal type, either 4-20 mA or 0-10 Vdc. If 4-20 mA is selected then the wiring is the same as for the ETP-9520, however if a 0-10 Vdc signal type is selected then a power supply signal must also be provided on the PWR terminal. Make sure that the shorting bars on the jumper run the same direction as the indicating lines beside the jumper. The ETP-9510 is a loop powered 2-10 volt device and requires a 2-10 Vdc signal to be connected to the INPUT terminal and the system common connected to the COM terminal.

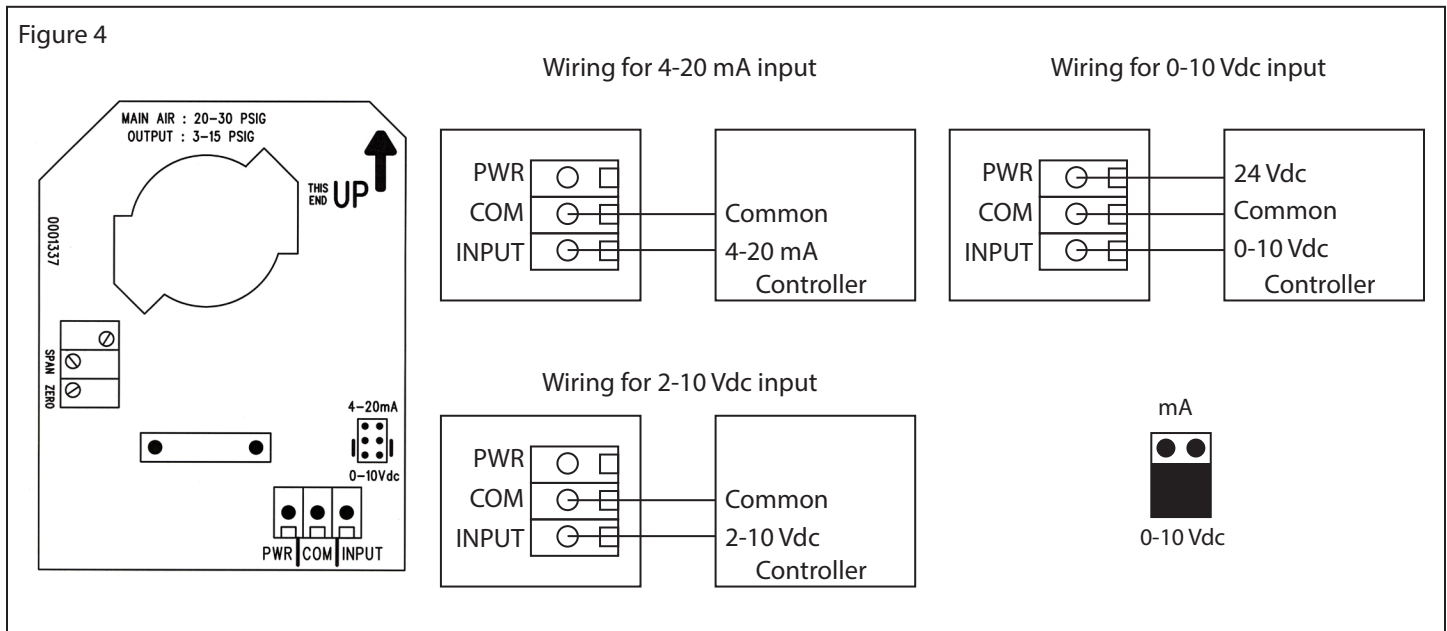

SPECIFICATIONS

SENSOR

Input Signal	ETP-9500: 4-20 mA or 0-10 Vdc, jumper selectable ETP-9510: 2-10 Vdc, 2 wire ETP-9520: 4-20 mA, 2 wire
Input Impedance	4-20 mA input: 400 Ω min, 550 Ω max 0-10 Vdc input: >100 K Ω
Power Supply	4-20 mA input: loop powered 0-10 Vdc input: 24-30 Vac/dc, 1.0 watt max
Air Supply	138 kPa (20 PSIG) nominal, 207 kPa (30 PSIG) max Clean, dry, oil-free air required
Air Consumption	5.66 ml/s (0.012 scfm) @ 138 kPa (20 PSIG) supply, max
Output Air Capacity	141 ml/s (515 SCIM) max @ 138 kPa (20 PSIG) supply
Air Connections	Male barbed fittings for flexible 1/4" OD pneumatic tubing
Output Signal	21-103 kPa (3-15 PSIG) nominal, direct acting
Linearity	$\pm 1\%$ of span
Hysteresis	$\pm 1\%$ of span
Adjustments	Zero and span potentiometers
Operating Temperature ...	0 to 60°C (32 to 140°F)
Operating Humidity	5-95 %RH non-condensing
Dimensions (snap track) ..	83mm Hx 70mm W x 50mm D (3.25" x 2.75" x 2")
Wiring Connections	Screw terminal block (14-22 AWG)
Manufacturing Process	ISO 9002 certified
Enclosure	ABS, UL94-5VB, IP61 (NEMA 2)

DIMENSIONS

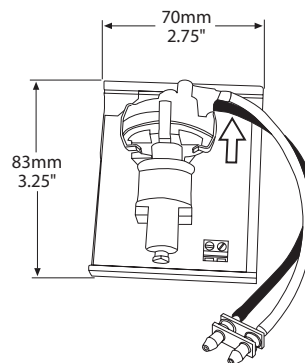
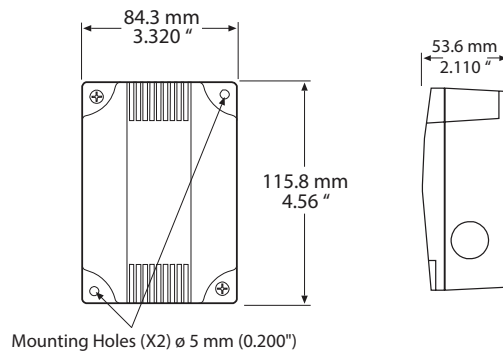

ACCESSORIES

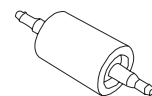

K-335 Filter