

INTRODUCTION

The spot water detector is used to detect the presence of water or conductive liquids. It is available with either one or two relay outputs and is designed to signal alarms if one or more of three conditions are met: water is detected, power is lost to the unit, or if there is an internal failure.

The spot water detector is housed in an IP65 rated enclosure with sensing probes protruding from the bottom. It features height adjustable mounting legs that include 5 preset mounting heights. An LED provides visual status indication.

BEFORE INSTALLATION

- Read these instructions carefully before installing and commissioning the water detector. Failure to follow these instructions may result in product damage.
- Do not use in an explosive or hazardous environment, with combustible or flammable gases, as a safety or emergency stop device or in any other application where failure of the product could result in personal injury.
- **Take electrostatic discharge precautions during installation and do not exceed the device ratings.**

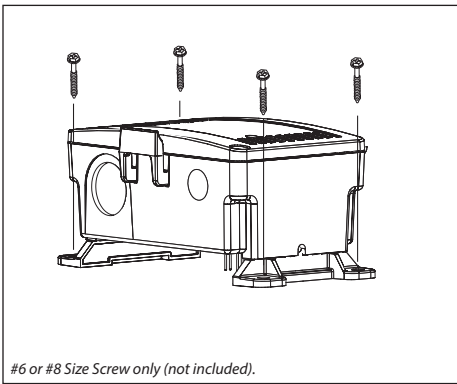

#6 or #8 Size Screw only (not included).

1 Select a suitable installation area to mount the device. Secure to the floor using silicone adhesive or with a #10 screw (not provided) using the integrated mounting holes.

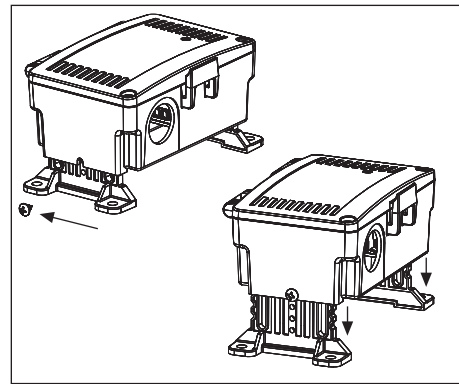

2 The legs have five pre-set heights. To adjust, remove screws from both legs. Pull/push the legs to the desired height, and re-insert screws.

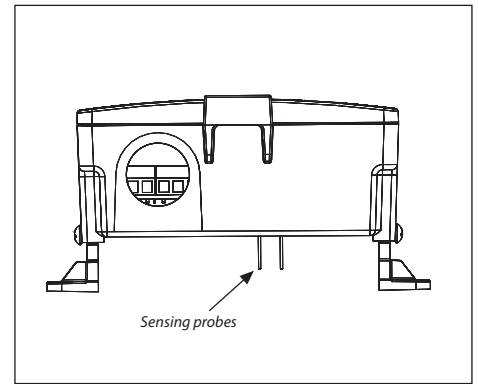

3 The sensing probes distance to floor is 1 mm (0.04") on lowest leg setting and 26.5 mm (1.04") on highest leg setting.

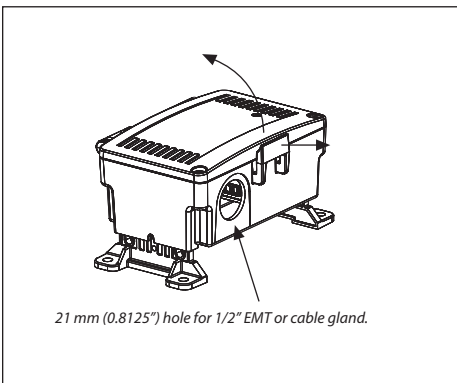

21 mm (0.8125") hole for 1/2" EMT or cable gland.

4 Open the cover by pulling slightly on the latch on the enclosure and at the same time pulling up on the cover.

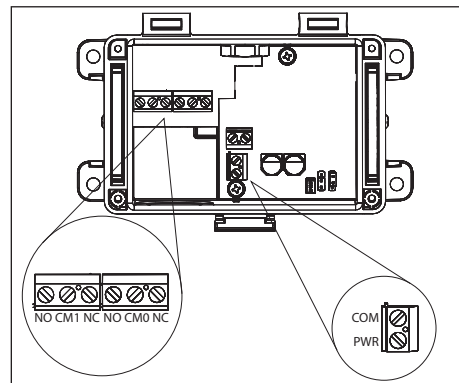

5 Make all connections in accordance with national and local codes. Use 14-22 AWG shielded wire and do not locate the device wiring in the same conduit with wiring used to supply inductive loads such as motors. The device is reverse voltage protected and will not operate if connected backwards.

NOTE: All jumpers are factory set. Do not change position. Changing jumper position will cause device to be in constant alarm state.

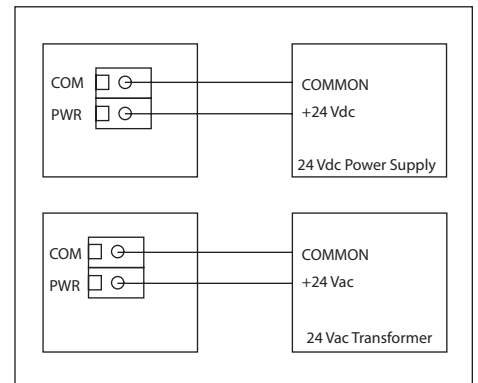

6 To prevent electrical shock or equipment damage make all connections before applying power. Connect 24 Vac/Vdc to PWR & COM terminals.

NOTE: Use caution when wiring multiple devices or when grounding the secondary of a transformer to ensure that the circuit ground point is the same on all devices and the controller.

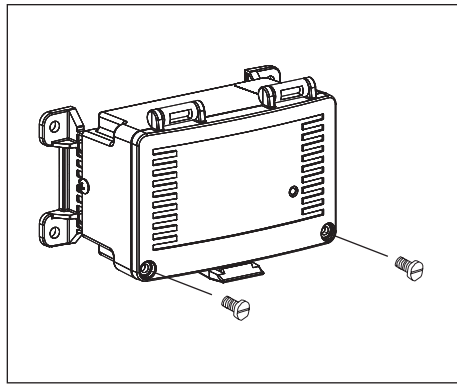
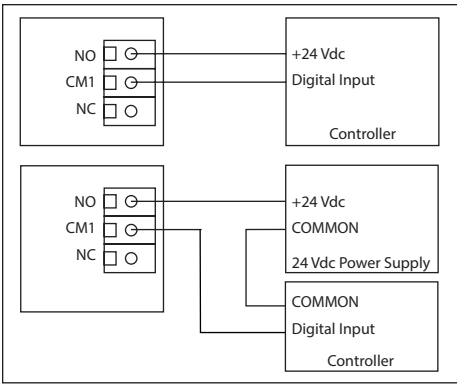

7 Do not exceed the device contact ratings. The relays are Form C type with both a normally open (NO) and a normally closed (NC) contact. Relay terminals are designated NO, CM* and NC.

8 Use the provided security screws to secure the cover.

NOTE: Each relay output is independent and isolated from the other and the relays COMs are not connected to the device COM.

OPERATION

When the sensor is powered on the controller will monitor the liquid detection channels. If a conductive liquid comes in contact with the sensor probes the controller will trigger the relay(s) to indicate liquid is present.

The relays are fail-safe, meaning when power is applied to device the relay is powered. If power is lost to device the relay will de-energize signaling a fault to the system.

1 Relay Model

Relay Activates on water detection or trouble.

2 Relay Model

Relay 1 and Relay 2 Activate on water detection or trouble.

LED: Green = No water

Red = Water Detection

SPECIFICATIONS

POWER SUPPLY	12 - 27 Vac/dc
SUPPLY CURRENT	125 mA max @ 24 Vac
ALARM OUTPUT	1 or 2 Form C relay(s), NO/NC, rated 2 Amps @ 30 VAC/VDC, 0.5 Amps @ 120 VAC (resistive load)
VISUAL INDICATION	Bi-color LED - Green, Red
OPERATING TEMPERATURE	0 to 50°C (32 to 122°F)
ENCLOSURE	ABS with hinged and gasket cover, IP65 (NEMA 4X)
DIMENSIONS	133.2mm L x 86.7mm W x 60.3-85.7mm H (5.2" x 3.4" x 2.4" - 3.4")
SENSOR PROBE HEIGHT	Adjustable, 1mm to 26 mm (0.04" to 1.04") - 5 pre-set heights
APPROVALS	CE, RoHS
COUNTRY OF ORIGIN	Canada

DIMENSIONS

