

**Introduction**

This water detector is a microchip-based device that uses conductivity cable to detect the presence of water or conductive liquids at any point along the cable. It is powered by an AC or DC source, 14 - 30 volts. It features Normally Open and Normally Closed (Form C) relay contacts rated at 4A @ 250 VAC/30 VDC for connection to a monitoring system, or direct control of another device. The water detector is designed to signal an alarm if one or more of three conditions are met: water is detected, power is lost to the unit, or if there is an internal failure.

**Before Installation**

Read these instructions carefully before installing and commissioning the water detector. Failure to follow these instructions may result in product damage. Do not use in an explosive or hazardous environment, with combustible or flammable gases, as a safety or emergency stop device or in any other application where failure of the product could result in personal injury. **Take electrostatic discharge precautions during installation and do not exceed the device ratings.**

**Mounting**

The water detector enclosure can be mounted directly to the floor of the area requiring monitoring or on a nearby wall. Select a suitable installation area that will enable enough room around the enclosure to allow for opening of cover and mounting of an EMT or cable gland connector. Once a suitable spot is selected, use the enclosure as a template and mark the 4 mounting hole locations.

Select suitable mounting hardware that is compatible with the surface that the water detector will be mounted to. As an example, if mounting on a wall with wallboard, the use of wall anchors is recommended to create a secure installation. The mounting holes will accommodate #10 size screws, as shown in Figure 1.

Once the enclosure is secured in place unroll conductivity cable and lay in place. The cable may be laid in a straight line or in a serpentine configuration. Be careful not to kink cable. Once laid in place, secure using the self-adhesive cable clips provided. For best results adhere clips at each end of the cable first. Clips are provided to secure cable approximately every 1.5 m (5'). See Figure 3.

The enclosure has a hinged cover with latch. Open the cover by pulling slightly on the latch on the right side of the enclosure and at the same time pulling on the cover, as shown in Figure 4.

A 21 mm (0.8125") hole is provided for connection of either a 1/2" conduit or cable gland style connector. Insert the conduit or cable gland connector through the hole and securely fasten using a locknut as shown in Figure 5.

Two security screws are provided which can be installed to help secure the cover once wiring connections are complete.

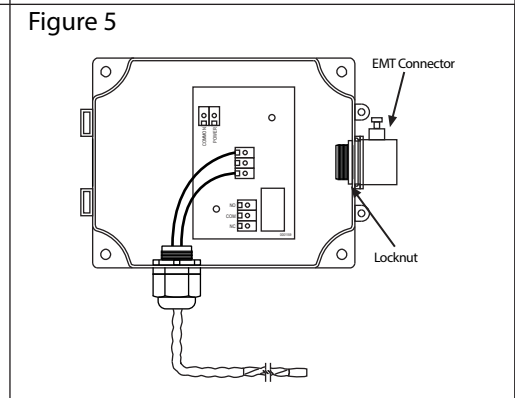
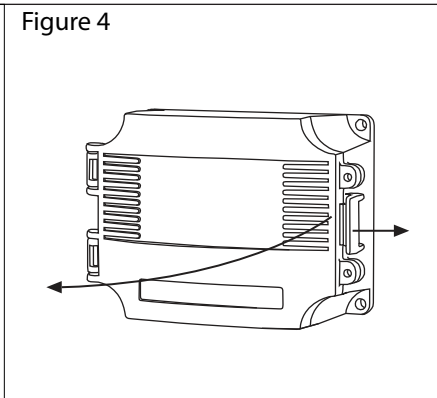
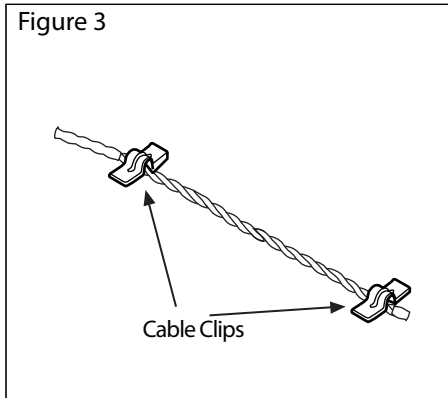
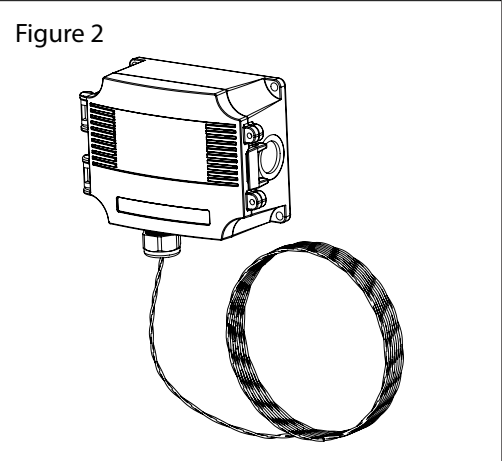
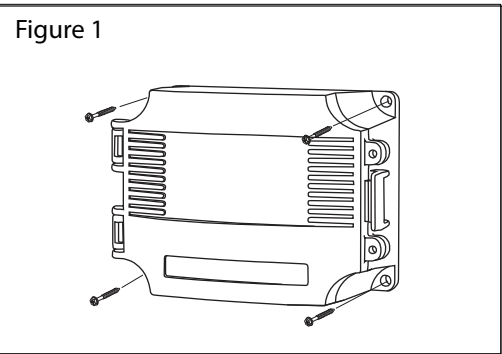

## Wiring

- **The conductivity cable is factory wired to the control board.**

- Deactivate the 24 Vac/dc power supply until all connections are made to the device to prevent electrical shock or equipment damage.
- Use 14-22 AWG shielded wiring for all connections and do not locate the device wires in the same conduit with wiring used to supply inductive loads such as motors. Make all connections in accordance with national and local codes.
- Pull at least six inches of control wire into the enclosure, then complete the wiring connection according to the wire diagram for the applicable power supply as shown in Figure 6.
- Connect the DC positive or the AC voltage hot side to the PWR terminal. The supply common is connected to the COM terminal. See Figure 6.
- The relay has both Normally Open (NO) and Normally Closed (NC) contacts available. The relay output is available on the NO/COM/NC terminal. Make connections before applying power as shown in Figure 7.
- Once all connections settings are verified, power can be applied.

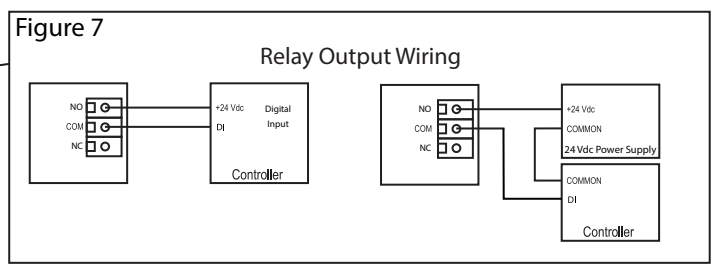
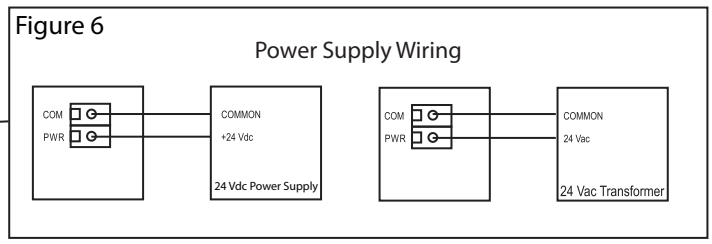
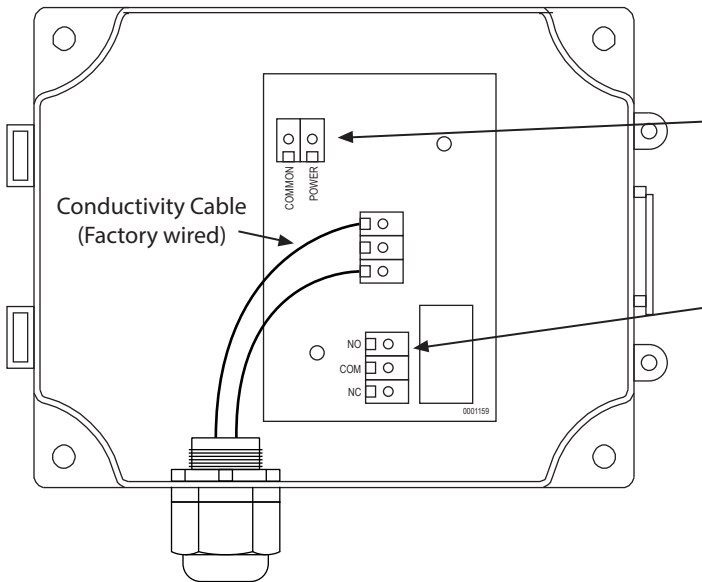

## Testing:

If field testing is required, simply pour a small amount of water at any point along the conductivity cable and relay will activate. Once water evaporates, the relay will de-activate.

## Specification:

- Power supply ..... 14 - 30 VAC/DC
- Supply current..... 60mA max @ 24 VDC,
- Operating temperature..... -40°C to 85°C (-40°F to 185°F)
- Enclosure ..... ABS with hinged lid and gasket  
IP65 (NEMA 4X), UL94-5VB
- Dimensions (LxWxH ..... 145 mm x 100 mm x 64 mm  
5.7" x 3.95" x 2.5"
- Alarm output..... Form C relay, rated @ 4 amps  
@ 250 VAC / 30 VDC  
(resistive load)
- Cable Rating ..... Plenum rated - CL2P (UL)
- Cable Length..... 1.5, 3, 7.6, 15.2, & 30.5 Meters  
(5', 10', 25', 50' & 100')  
Custom lengths available

## Ordering Information

- WD-100-5 - c/w 1.5 m (5') conductivity cable
- WD-100-10 - c/w 3 m (10') conductivity cable
- WD-100-25 - c/w 7.6 m (25') conductivity cable
- WD-100-50 - c/w 15.2 m (50') conductivity cable
- WD-100-100 - c/w 30.5 m (100') conductivity cable

## Dimensions:

